



# QuadGuard<sup>®</sup> M10 [24"]

CRASH CUSHIONS

PRODUCT MANUAL



**PN 625877**

AUGUST 2022

# QuadGuard® M10 [24"]

The QuadGuard® M10 has been tested pursuant to American Association of State Highway and Transportation Officials (“AASHTO”) Manual for Assessing Safety Hardware (“MASH”) specifications. The QuadGuard® M10 has been deemed eligible for federal-aid reimbursement on the National Highway System by the Federal Highway Administration (“FHWA”).

## Product Description Assembly Manual



15601 Dallas Parkway  
Suite 525  
Addison, Texas 75001



**Warning:** The local highway authority, distributors, owners, contractors, lessors, and lessees are **RESPONSIBLE** for the assembly, maintenance, and repair of the QuadGuard® M10. Failure to fulfill these **RESPONSIBILITIES** could result in serious injury or death.



**Important:** These instructions are for standard assembly specified by the appropriate highway authority. In the event the specified system assembly, maintenance, or repair would require a deviation from standard assembly parameters, contact a Valtir representative. This system has been deemed eligible by the FHWA for use on the national highway system under strict criteria utilized by that agency.

**This manual must be available to workers overseeing and/or assembling the product at all times. For additional copies, contact Valtir at (888) 323-6374 or visit [Valtir.com](http://Valtir.com).**

The information contained in this manual supersedes all previous versions. The instructions, illustrations, and specifications are based on the latest QuadGuard® M10 information available to Valtir at publication. We reserve the right to make changes at any time. Please visit [Valtir.com/Product/QuadGuard M10](http://Valtir.com/Product/QuadGuard M10) to confirm the latest revision.

## Table of Contents

Customer Service Contacts .....	3
Important Introductory Notes .....	3
Safety Symbols .....	4
Safety Rules for Assembly .....	4
Limitations and Warnings.....	5
System Overview .....	6
Inspect Shipping.....	6
System Components.....	7
Determine Transition Type.....	<b>Error! Bookmark not defined.</b>
Recommended Tools.....	12
Site Preparation/Foundation .....	14
Foundation/Anchoring.....	15
Valtir Approved Adhesive Anchoring System .....	16
Vertical Anchors.....	16
Anchor Assembly Cautions.....	17
Horizontal Anchors.....	18
System Assembly .....	21
QuadGuard® M10 24" Final Inspection Checklist.....	34
Maintenance and Repair.....	35
Inspection Frequency.....	35
Visual Drive-By Inspection .....	35
Walk-Up Inspection Checklist .....	35
Post-Impact Instructions.....	36
Parts Ordering Procedure & Drawings.....	38
Parts List(s) & Quantities .....	38
QuadGuard® M10 w/ Tension Strut Backup QGMTSCVR-U.....	40
TS Concrete Pad 618686.....	41
TS Concrete Pad 8" w/Rebar 618686 .....	42
TS Concrete Pad 8" wo/Rebar 618686 .....	43
Tension Strut Backup 627448 .....	44
Monorail Assembly 625637 .....	45
Diaphragm Assembly 625650 .....	46
Shim Kit 627518.....	47
Fender Panel Assembly 608236 .....	48
Nose Assembly 626814.....	49
31" W-Beam Guardrail Transition QGMTSCVR-TWLR.....	50
Thrie-Beam Guardrail Transition QGMTSCVR-TTLR .....	51
Safety Shape Barrier Transition QGMTSCVR-T4 .....	52
Single Slope Transition QGMTSCVR-T6 .....	53
Vertical Barrier Transition QGMTSCVR-ES .....	54
Vertical Barrier Transition, Extended QGMTSCVR-SPE.....	55

## Customer Service Contacts

Valtir is committed to the highest level of customer service. Feedback regarding the QuadGuard® M10, its assembly procedures, supporting documentation, and performance is always welcome. Additional information can be obtained from the contact information below:

### Valtir

Telephone	(888) 323-6374 (USA) +1 312 467-6750 (International)
Contact Link	<a href="http://Valtir.com/Contact">Valtir.com/Contact</a>

## Important Introductory Notes

Proper assembly of the QuadGuard® M10 is critical to achieve tested performance that has been evaluated and deemed eligible by the FHWA per AASHTO MASH criteria. These instructions should be read and understood in their entirety before assembly. These instructions are for standard assemblies and used in conjunction with the assembly of the QuadGuard® M10 as specified by the applicable highway authority. If you need additional information, or have questions about the QuadGuard® M10, please contact the highway authority that has planned and specified this assembly and, if needed, contact Valtir. This product must be assembled in the location specified by the appropriate highway authority. If there are deviations, alterations, or departures from the assembly protocol specified in this manual, the device may not perform as tested.



**Important: DO NOT** use any component part that has not been specifically specified herein for the QuadGuard® M10 during the assembly or repair of this system (p. 7 – 10 / 38 - 39).

This product has been specified for use by the appropriate highway authority and has been provided to that user who has unique knowledge of how this system is to be assembled. No person should be permitted to assist in the assembly, maintenance, or repair of this system that does not possess the unique knowledge described herein. These instructions are intended for an individual qualified to both read and accurately interpret them as written. These instructions are intended only for an individual experienced and skilled in the assembly of highway products that are specified and selected by the highway authority.

A manufacturer's drawing package will be supplied by Valtir upon request. Each system will be supplied with a specific drawing package unique to that system. Such drawings take precedence over information in this manual and shall be studied thoroughly by a qualified individual who is skilled in interpreting them before the start of any product assembly.

## Safety Symbols

This section describes the safety symbols that appear in this manual. Read the manual for complete safety and assembly information.

### Symbol

### Meaning



**Safety Alert Symbol:** Indicates Important, Caution, Warning, or Danger. Failure to read and follow the Important, Caution, Warning, or Danger indicators could result in serious injury or death to workers and/or bystanders.



**Warning:** Read safety instructions thoroughly and follow the assembly directions and suggested safe practices before assembling, maintaining, or repairing the QuadGuard® M10. It is the responsibility of the installer to follow the instructions contained in this manual. Failure to comply with these warnings could result in increased risk of serious injury or death in the event of a vehicle impact.



**Important:** Please keep up-to-date instructions for later use and reference by anyone involved in the assembly of the product.

## Safety Rules for Assembly

### \* Important Safety Instructions \*

This manual must be kept in a location where it is readily available to persons who are skilled and experienced in the assembly, maintenance, or repair of the QuadGuard® M10. Additional copies of this manual are available from Valtir by calling (888) 323-6374 or by visiting [Valtir.com/Product/QuadGuard M10](http://Valtir.com/Product/QuadGuard M10). Please contact Valtir if you have any questions concerning the information in this manual or about the QuadGuard® M10.

It is the responsibility of the installer to use appropriate safety precautions when operating power equipment, mixing chemicals, and when moving heavy equipment or QuadGuard® M10 components. Safety articles including but not necessarily limited to work gloves, eye protection, safety-toe shoes, and back protection should be used.



**Warning:** It is the responsibility of the installer to use all safety measures incorporating appropriate traffic control devices specified by the highway authority. These measures must be used to protect all personnel while at the assembly, maintenance, or repair site.



**Warning:** Failure to comply with these warnings could result in increased risk of serious injury or death in the event of a vehicle impact with a system that has not been accepted by the FHWA.



**Warning:** Use only Valtir parts on the QuadGuard® M10 for assembly, maintenance, or repair. The use of component parts not specified herein is **strictly prohibited**. The QuadGuard® M10 assembled with Valtir parts has been tested, approved, and accepted for use by the FHWA. A QuadGuard® M10 using parts other than those specified herein has not been tested, approved, or accepted for use by the FHWA. Failure to follow this warning could result in increased risk of serious injury or death in the event of a vehicle impact.

## **Limitations and Warnings**

Pursuant to MASH “Recommended Procedures for the Safety Performance of Highway Safety Features”, Valtir contracts with FHWA approved testing facilities to perform and evaluate crash tests to prepare a crash test results report. Valtir is then able to submit a Request for Federal Aid Reimbursement of Safety Hardware Devices to the FHWA for review.

The QuadGuard® M10 has been deemed eligible by FHWA as meeting the requirements and guidelines of MASH. These tests evaluate product performance defined by AASHTO involving lightweight cars (approx. 2420 lb. [1100 kg]) and full size pickup trucks (approx. 5000 lb. [2270 kg]). A product can be certified for multiple Test Levels. The QuadGuard® M10 is certified to the Test Level(s) as shown below:

**Test Level 3: 62 mph [100 kph]**

**Test Level 2: 44 mph [70 kph]**

**These AASHTO directed tests are not intended to represent the performance of systems when impacted by every vehicle type or every impact condition existing on the roadway. This system is tested only to the test matrix criteria of MASH as approved by FHWA.**

Valtir expressly disclaims any warranty or liability for injury or damage to persons or property resulting from any impact, collision or harmful contact with products, other vehicles, or nearby hazards or objects by any vehicle, object or person, whether or not the products were assembled in consultation with Valtir or by third parties.

The QuadGuard® M10 is intended to be assembled, delineated, and maintained within specific state and federal guidelines. It is important for the highway authority specifying the use of a highway product to select the most appropriate product configuration for site specifications. The customer should be careful to properly select, assemble, and maintain the product. Careful evaluation of site layout, traffic speed/type, direction, and visibility are some of the elements that require evaluation by the highway authority in the selection of a highway product. For example, curbs could cause an untested effect on an impacting vehicle.

After an impact occurs, the debris from the impact should be removed from the area immediately and the specified highway product should be evaluated and restored to its original specified condition or replaced as the highway authority determines as soon as possible.



**Warning:** Do not assemble, maintain, or repair the QuadGuard® M10 until you have read this manual thoroughly and completely understand it.



**Warning:** Ensure that all Danger, Warning, Caution, and Important statements within this manual are completely followed. Failure to follow this warning could result in serious injury or death in the event of a collision.

## System Overview

The QuadGuard® M10 is a re-directive, non-gating crash cushion for roadside features of 24" [610 mm] or greater in width with use of approved transitions. It consists of energy-absorbing cartridges surrounded by a framework of Quad-Beam Fender Panels.



**Important:** Valtir makes no recommendation whether use or reuse of any part of the system is appropriate or acceptable following an impact. It is the sole responsibility of the project engineer and/or the local highway authority and its engineers to make that determination. It is critical that you inspect this product after assembly is complete to make certain that the instructions provided in this manual have been strictly followed.

The QuadGuard® M10 utilizes two types of cartridges in a “staged” configuration that are designed and tested to address vehicles as defined by MASH for both lighter cars and heavier, high center-of-gravity vehicles.

### **Impact Performance**

The six (6) Bay QuadGuard® M10 has successfully passed the requirements stipulated in MASH with both the light car and pickup trucks at speeds of up to 62 mph [100 kph] at redirection angles up to 25 degrees.

The three (3) Bay QuadGuard® M10 has successfully passed the requirements stipulated in MASH with both the light car and pickup trucks at speeds of up to 44 mph [70 kph] at redirection angles up to 25 degrees.

During head-on impact testing, within MASH criteria, the QuadGuard® M10 has been shown to telescope rearward to absorb the energy of impact. When impacted from the side, within the applicable MASH criteria, it has been shown to redirect the vehicle back toward its original travel path and away from the highway feature.



**Warning:** It is the sole responsibility of the project engineer and/or local highway authority and its engineer to ensure that the QuadGuard® M10 and delineation used meet all federal, state, specifying agency, and local specifications.



**Warning:** It is the sole responsibility of the project engineer and/or local highway authority and its engineer to ensure that the QuadGuard® M10 meets all appropriate Manual on Uniform Traffic Control Devices (“MUTCD”) and local standards.

### **Inspect Shipping**

Check the received parts against the shipping list supplied with the system before deploying the QuadGuard® M10. Make sure all parts have been received (p. 38 - 39).



**Important:** The Manufacturer’s Drawing Package supplied with the QuadGuard® M10 must be used with these instructions for proper assembly and should take precedence over these general instructions.

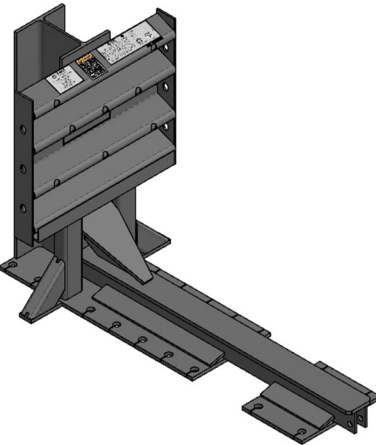
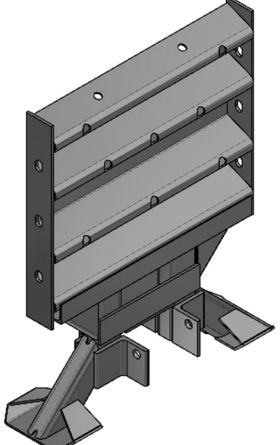
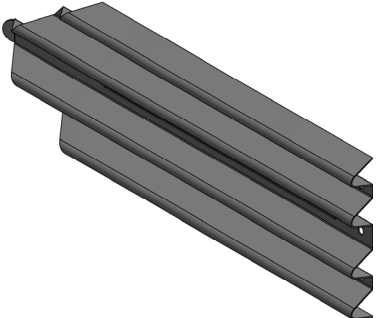

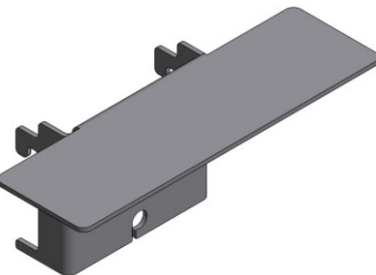
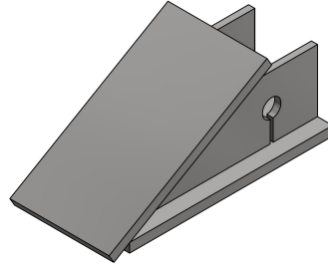

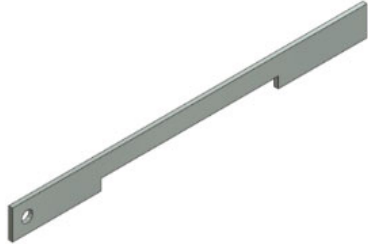
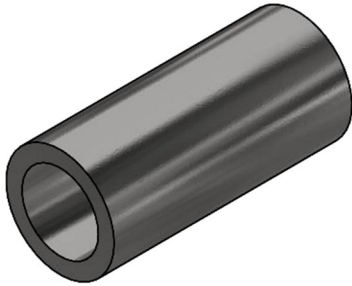


**Warning:** Do NOT modify the QuadGuard® M10 in any way.


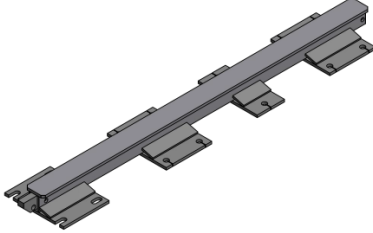
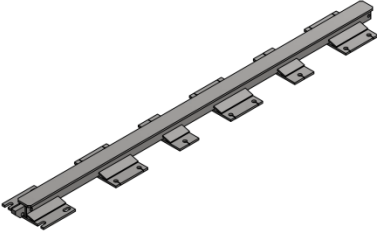
## System Components

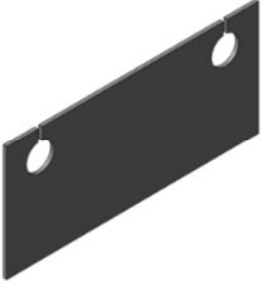


Below is a list of system components that may be used in your particular QuadGuard® M10 configuration. Verify parts delivered and system details with the BOM (Bill of Materials) and system drawings shipped with your system. Please call Valtir if you have any system questions (p. 3).

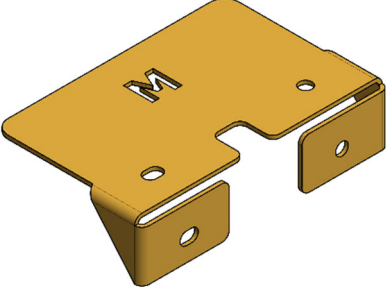
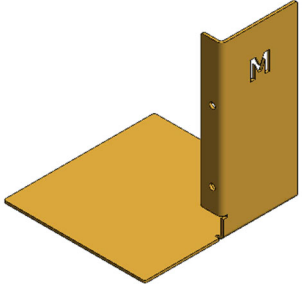
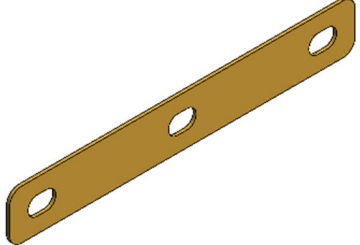
**Note:** Components are not shown to scale.

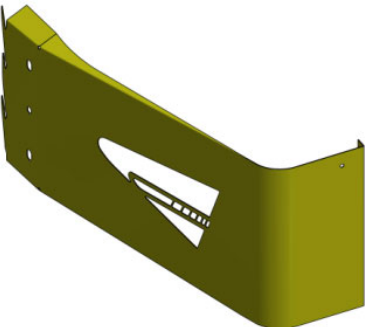
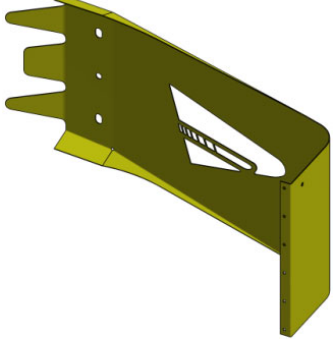
<p>Tension Strut Backup 24"</p>  <p>626055</p>	<p>Diaphragm 24"</p>  <p>625647</p>	<p>Panel, Fender, QG</p>  <p>611832</p>
<p>Panel, Side, QG</p>  <p>611898</p>	<p>Bracket, Cartridge Support</p>  <p>605446</p>	<p>End Cap, Monorail, QG, G</p>  <p>608136</p>
<p>Bracket, Cartridge Support TS B/U</p>  <p>605447</p>	<p>Locking Bar, Cartridge Support</p>  <p>611266</p>	<p>Pipe, 3/4" Sch 80X3</p>  <p>627537</p>

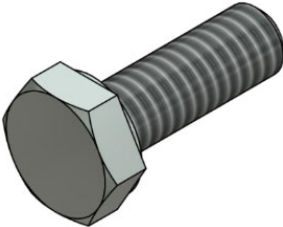
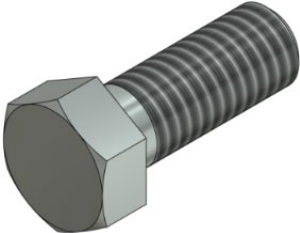
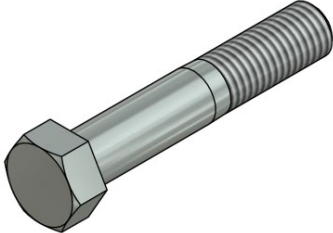



Monorail Guide 	Monorail, Two Bays, QG, G 	Monorail, Three Bays, QG, G 
611368	611375	611379


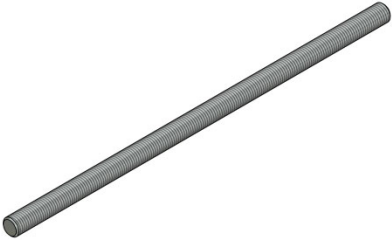
Shim, 12GAX3 5/8X8 	Bracket, Angle, 2X1, W/Holes 	Bracket, Pull-Out 
614062	626817	605535

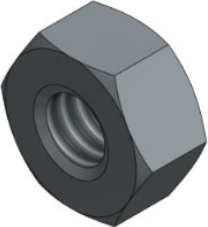
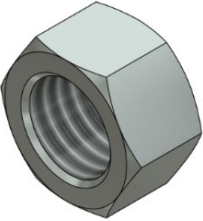
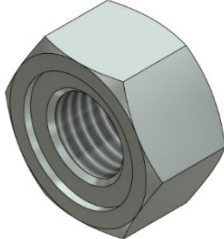
Bracket, Cart, Hold Down 	Bracket, Cart Support, Nose 	Washer, Bar, 1/4 
626815	626816	626818

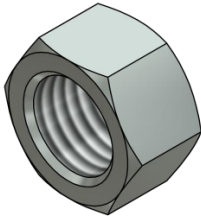
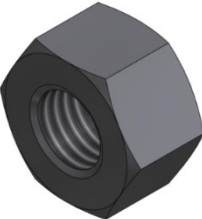
Nose, L, W/Logo 	Nose, R, W/Logo 
611669	611680







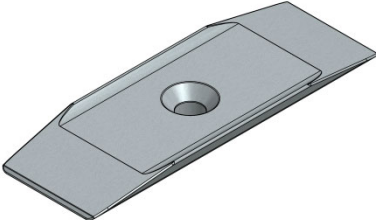
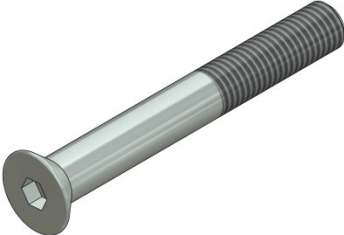




Bolt, Hex, 1/4X3/4, G5	Bolt, Hex, 3/8X1, G5	Bolt, Hex, 5/8X3 1/2, G5
		
113518	113596	113660

Rail Bolt, 5/8X2	Bolt, Rail 5/8-11X5	Bolt, Hex, 3/4X2, G8
		
003400	004441	113555

Anchor, 3/4X6 1/2, G5	Anchor, 3/4X7, G5	Anchor, 3/4X18, G5
		
117540	117542	116799

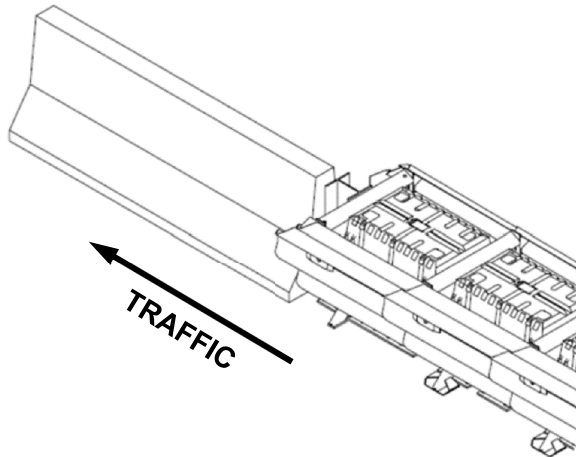
Nut, Hex, 1/4	Nut, Hex, 3/8	Rail Nut, Hex, 5/8
		
115946	115960	003340

Nut, Hex, 5/8	Nut, Heavy Hex, 3/4
	
003354	003704

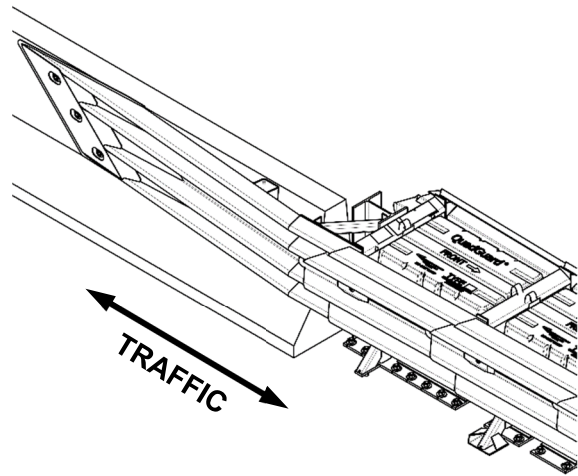
<p>Washer, Lock, 5/8</p>  <p>118100</p>	<p>Washer, Lock, 3/4</p>  <p>118089</p>	<p>Washer, Flat 3/8X1</p>  <p>118036</p>
<p>Washer, Flat, 5/8X1 3/4</p>  <p>003300</p>	<p>Washer, Fender, 3/8X2</p>  <p>118038</p>	<p>Washer, Flat, 3/4X2</p>  <p>118027</p>
<p>Mushroom Washer</p>  <p>617045</p>	<p>Flat Screw 5/8X5,G8</p>  <p>116878</p>	<p>Die Spring, 5/8 X 1 1/2</p>  <p>117459</p>
<p>Cartridge Assy, Type I</p>  <p>606027</p>	<p>Cartridge Assy, Type II</p>  <p>606029</p>	<p>Approved Adhesive</p>  <p>118710</p>

## Select Transition

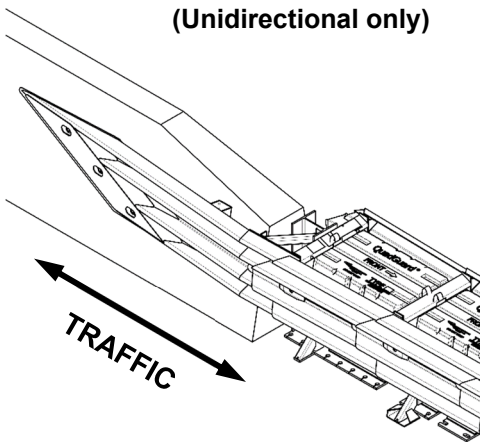
**Note:** A proper Transition Panel or Side Panel must be used on each side of the Backup. A Side Panel is not needed when a Transition Panel is used. The correct Panel(s) to use will depend on the direction of traffic and what type of barrier or road feature the QuadGuard® M10 is shielding. Contact the Customer Service Department prior to deployment if you have any questions (p. 3).



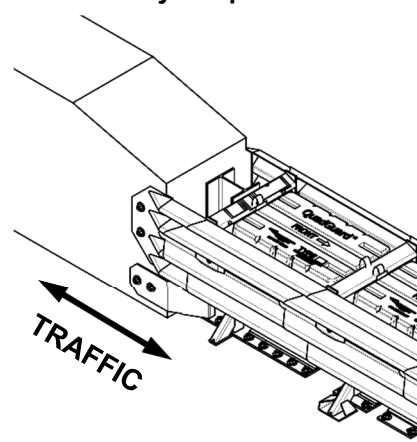
**Figure 1**  
No Transition  
(Unidirectional only)



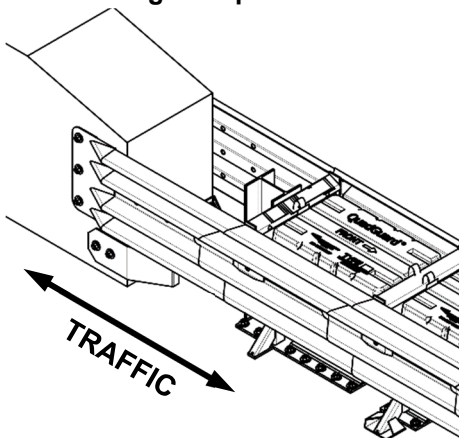
**Figure 2**  
Safety Shape 4'' Offset



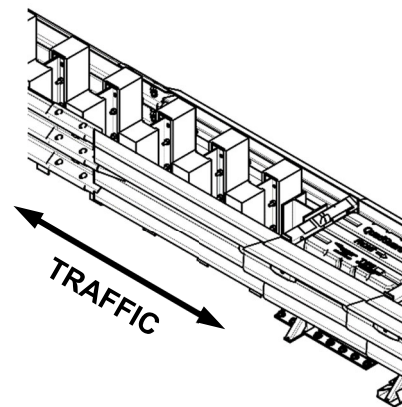
**Figure 3**  
Single Slope 6'' Offset



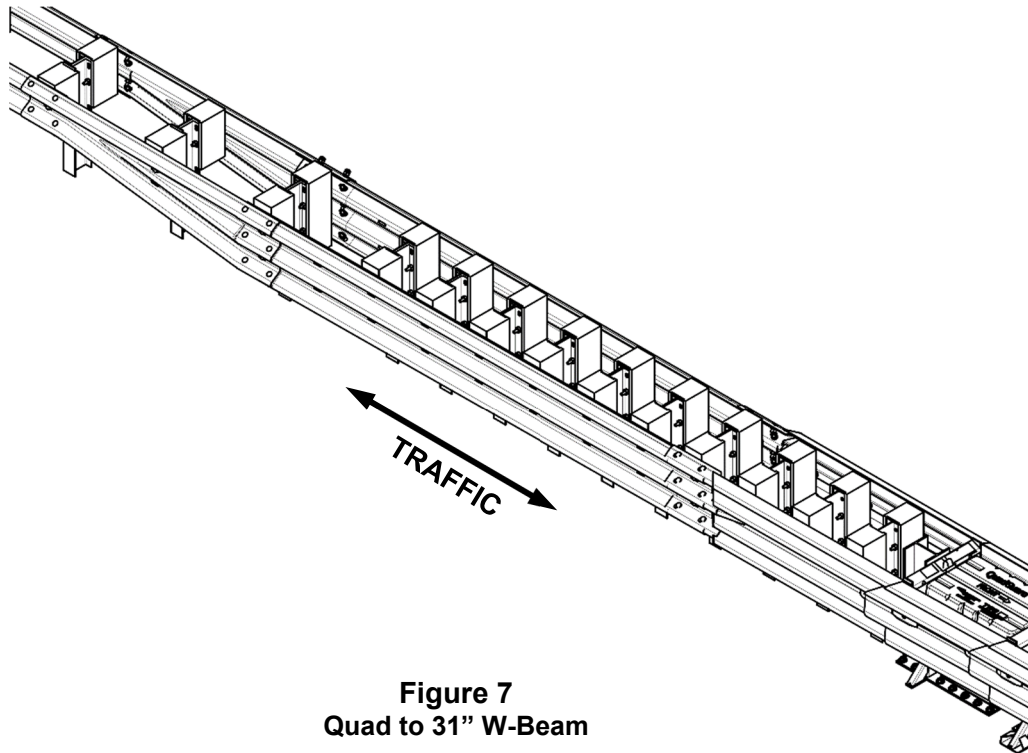
**Figure 4**  
End Shoe



**Figure 5**  
Extended End Shoe



**Figure 6**  
Quad to Thrie-Beam



**Figure 7**  
**Quad to 31" W-Beam**

## **Recommended Tools**

### **Documentation**

- Manufacturer's Assembly Manual
- Manufacturer's Drawing Package

### **Personal Protective equipment**

- Eye Protection
- Gloves
- Safety-toe Shoes
- Protective Clothing
- Reflective Vest

### **Cutting equipment**

- Rotary Hammer Drill
- Rebar cutting bit
- Concrete drill bits – 7/8" [22 mm] (**Double-Fluted**)
- Grinder, Hacksaw or Torch (optional)



**Important:** Valtir recommends using **double-fluted** drill bits to achieve optimum tensile strength when applying an approved adhesive anchoring system (p. 15).

## Hammers

- Sledgehammer
- Standard hammer

## Wrenches

- Heavy duty 1/2" drive impact wrench
- 1/2" drive sockets: 7/16", 9/16", 15/16", 1 1/16", 1 1/8", 1 1/4"
- 1/2" drive Deep well sockets: 15/16", 1 1/4"
- 1/2" drive Ratchet and attachments
- 1/2" drive Breaker bar – 24" long
- 1/2" drive Torque wrench: 200 ft-lb
- Combination wrench(s): 7/16", 9/16", 15/16", 1 1/8"
- Hex Key (Allen) wrench: 3/8"



**Important:** Valtir makes no recommendation whether use or reuse of any part of the system is appropriate or acceptable following an impact. It is the sole responsibility of the project engineer and/or the local highway authority and its engineers to make that determination. It is critical that you inspect this product after assembly is complete to make certain that the instructions provided in this manual have been strictly followed.

## Miscellaneous

- Traffic control equipment
- Lifting and moving equipment (A lifting device is preferred although a forklift can be used.) Minimum 5,000 lb. capacity required.
- Air Compressor (100 psi minimum) and Generator (5 kW)
- Long pry bar
- Drift pin 12" [300 mm]
- Center punch
- Tape measure 25' [7.5 m]
- Chalk line
- Concrete marking pencil
- Steel bristled tube brush for cleaning 7/8" drilled boreholes
- Rags, water, and solvent for touch-up

**Note:** The provided list of tools is a general recommendation and should not be considered an extensive list. Depending on specific site conditions and the complexity of the assembly specified by the appropriate highway authority, the required tools may vary. Decisions as to what tools are needed to perform the job are entirely the responsibility of the specifying highway authority and the authority's selected contractor performing the assembly of the system at the authority's specified assembly site.

## Site Preparation/Foundation

A QuadGuard® M10, for permanent applications, should be assembled on an existing or freshly placed and cured concrete base (28 MPa [4000 psi] minimum). Location and orientation of the concrete base and attenuator must comply with project plans or as otherwise determined by the local highway authority.

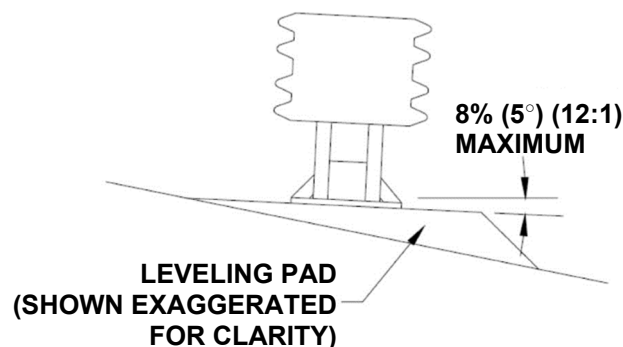
Recommended dimension and reinforcement specifications for new concrete foundations are provided in Valtir concrete foundation drawings, supplied with the system. The system may be assembled on a non-reinforced concrete roadway (minimum 8" [200 mm] thick). Deployment cross-slope shall not exceed 8% and should not twist more than 2% over the length of the system; the foundation surface shall have a light broom finish.



**Warning:** It is the responsibility of the installer to ensure proper site grading for the QuadGuard® M10 placement as dictated by the state or specifying agency pursuant to the AASHTO Roadside Design Guide.



**Caution:** Accurate placement of all steel rebar is critical to avoid interference with the concrete anchor bolts.



**Figure 8**  
**Cross-Slope**



**Warning:** Location of the Backup in relation to nearby objects will affect the operation of the attenuator. Upon impact, the Fender Panels telescope rearward and extend beyond the rigid Backup as much as 30" [760 mm]. Position the Backup so that the rear ends of the last Fender Panels are a minimum of 30" [760 mm] forward of objects that would otherwise interfere with movement of the rearmost Fender Panels. Failure to comply with this requirement is likely to result in system performance which has not been crash tested pursuant to MASH criteria and may also cause component damage which will necessitate maintenance or replacement of the system.



**Important:** Systems mounted on asphalt must be replaced and mounted on fresh, undisturbed asphalt if more than 10% of anchors are found to be loose, broken, or show signs of pull out. If 10% or fewer anchors are damaged, replace the damaged anchors in the existing asphalt. Anchor bolts used on systems mounted on asphalt must be inspected every 6 months. Review Maintenance and Repair Instructions and Post-Impact Instructions (pp. 35-38).

## Foundation/Anchoring



**Important:** It is the responsibility of the local DOT or appropriate highway authority to ensure that this assembly conforms to the AASHTO Roadside Design Guide.



**Warning:** It is the responsibility of the installer to ensure that your assembly procedure meets all appropriate Occupational Safety and Health Administration (“OSHA”) and local standards.

### Asphalt Installations

Systems with a Tension-Strut Backup may be temporarily installed in construction zones on asphalt. Assemblies on **Asphalt Concrete (“A.C.”)** must provide a minimum of 3” [76 mm] layer of asphalt over a minimum of 3” [76 mm] layer of **Portland Cement Concrete (“P.C.C.”)**, 6” [152 mm] layer of asphalt over 6” [152 mm] layer of subbase, or 8” [200 mm] layer of asphalt with no subbase.



**Important:** Only 18” [460 mm] threaded rods, utilizing Valtir approved adhesive, can be used with **asphalt** foundations (p. 15). Contact Valtir for a complete list of approved adhesives (p. 3).

### Concrete Installations

For concrete installations, the QuadGuard® M10 should be installed only on an existing or freshly placed and cured concrete base (4000 psi [28 MPa] minimum). Orientation of the concrete base and the attenuator must comply with the project plans or as otherwise determined by the resident project engineer or appropriate highway authority.

Recommended dimension and reinforcement specifications for new concrete pads can be found on the standard drawings.

The QuadGuard® M10 may be installed on any of the following foundations using the specified anchorage:

#### Foundation A: Reinforced Concrete Pad or Roadway

Foundation: 6” [152 mm] minimum depth P.C.C.

Anchorage: Approved adhesive with 7” [180 mm] studs 5 1/2” [140 mm] embedment

#### Foundation B: Asphalt over P.C.C.

Foundation: 3” [76 mm] minimum asphalt concrete (A.C.) over 3” [76 mm] minimum P.C.C.

Anchorage: Length of anchor required is 18” [460 mm] and embedment of 16 1/2” [420 mm]

#### Foundation C: Asphalt over Subbase

Foundation: 6” [152 mm] minimum A.C. over 6” [152 mm] minimum Compacted Subbase (C.S.)

Anchorage: Approved adhesive with 18” [460 mm] studs 16 1/2” [420 mm] embedment

#### Foundation D: Asphalt Only

Foundation: 8” [200 mm] minimum A.C.

Anchorage: Approved adhesive with 18” [460 mm] studs - 16 1/2” [420 mm] embedment



# Valtir Approved Adhesive Anchoring System

A Valtir approved adhesive anchoring system is required to securely anchor crash cushions. Each approved adhesive kit contains adhesive, studs, nuts and washers. Both vertical and horizontal assemblies are possible using an approved adhesive anchoring system.

## Vertical Anchors

**Note:** Read all Valtir approved adhesive instructions before starting.

### 1) Prepare the Concrete Foundation



**Warning:** Do not allow anchoring adhesive to contact skin or eyes. See material safety data sheet supplied with adhesive kit for first-aid procedures. Use only in well-ventilated area. Do not use near open flame.



**Warning:** It is the responsibility of the installer to maintain a safe work area including the use of standard work zone safety equipment & PPE: gloves, safety-toe shoes, and eye / ear protection.

The anchor bolts (studs) that anchor the QuadGuard® M10 Backup and/or Monorail sections to the concrete foundation must be those shipped in the kit or of high strength steel (120,000 psi [830 MPa] minimum tensile strength or equal). These studs must be set in minimum 4000 psi [28 MPa] concrete. Allow the concrete to cure a minimum of seven days before applying anchoring adhesive.

### 2) Drill Boreholes



**Caution:** It is the responsibility of the installer to consult OSHA silica respiratory standard 29 CFR 1910.134 for debris removal from borehole(s) and use Valtir approved adhesive to achieve optimum tensile strength. Do not use diamond drill bits for drilling boreholes.

Use the Monorail(s) and Tension Strut Backup as drilling templates. Use a rotary hammer drill to drill the boreholes 7/8" [22 mm] diameter to the recommended depth. See the approved adhesive instructions provided with adhesive kit. Check ensure each borehole is drilled to the proper depth and aligned with the part to be anchored per Anchoring Information table.

Anchoring Information					
Stud Size:	Orientation	Bit Size	Minimum Depth	Torque	Medium
3/4"x 7"	Vertical	7/8" [22 mm]	5 3/4" [145 mm]	Manufacturer Spec	Concrete
3/4"x 18"	Vertical	7/8" [22 mm]	16 3/4" [425 mm]	10 ft-lb [15 N-m]	Asphalt



**Important:** When mounting on asphalt, initial torque shall be as shown above. Due to the properties of asphalt, anchors may loosen over time. For this reason Valtir recommends anchoring to asphalt only at temporary locations. It is recommended to re-torque anchors in asphalt every six (6) months to the proper initial torque specified.

### 3) Clean the Boreholes

Blow the concrete dust from the borehole using oil-free compressed air. Thoroughly brush it with a 7/8" diameter steel bristle tube brush and then blow it out again. If the borehole is wet, completely flush it with water while brushing and then blow it clean to remove all water using oil-free compressed air.

**Note:** Use of the Valtir approved vacuum drilling equipment is authorized to replace the blowing and brushing requirement of Step 3.

### 4) Apply Approved Adhesive

Fill the borehole 100% full.



**Caution:** Fill borehole 100% full so it is even with the pavement surface per manufacturer's instructions.

### 5) Add the Washers and Nuts

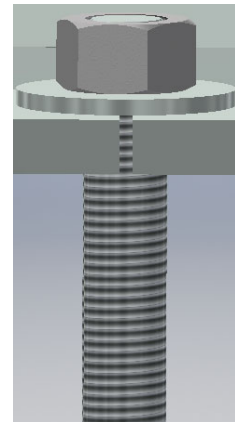
Place a flat washer onto the stud then thread a nut on until the end of the stud is flush with the nut (Figure 9).

### 6) Insert Studs in Boreholes and Wait for Adhesive to Cure

Push the stud down through the part to be anchored and into the borehole.



**Caution:** Do not disturb or load the stud until the approved adhesive material has fully cured (reference instructions supplied with the approved adhesive kit).



**Figure 9**  
**Vertical Application**  
**(Before Applied Torque)**

### 7) Torque the Nuts

Once the adhesive has fully cured, torque the nut to the adhesive manufacturer's recommended values.

## Anchor Assembly Cautions

### 1) Steel rebar

If steel rebar is encountered while drilling an anchor bolt borehole, apply one of the following solutions:

A) Use a rebar drill bit for the **rebar only** and then switch back to the concrete bit to finish drilling into the underlying concrete until the proper borehole depth is reached.



**Caution:** Do not drill through rebar without first obtaining permission to do so from the project engineer.

B) Drill a new borehole down at an angle past the rebar to the proper depth. Anchor the stud by completely filling both boreholes with an approved adhesive.

## Horizontal Anchors

The horizontal approved adhesive kit is the same as the vertical kit.



**Caution:** Fill borehole 100% full so it is even with the vertical concrete surface per manufacturer's instructions.

### 1) Follow the instructions supplied with your approved adhesive kit

Apply approved adhesive to each anchor per instructions.

### 2) Add the Washers and Nuts

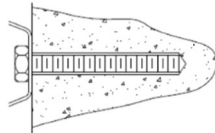
Put washer and nut on stud so the **nut is flush with end of stud**.

### 3) Insert each Stud with Washer and Nut into Borehole

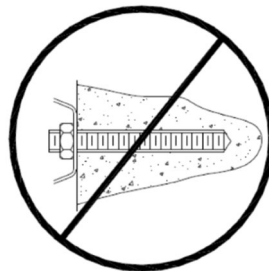
Push stud with washer and nut into borehole.



**Important:** The stud should be flush with the top of the nut in both **vertical** and **horizontal** applications prior to tightening (Figure 10).



**CORRECT**



**INCORRECT**

**Figure 10**  
**Horizontal Application**  
**(Before Applied Torque)**



**Caution:** Do not disturb or load the stud until the approved adhesive material has hardened (reference approved adhesive kit instructions for hardening times).

### 4) Torque the nuts

Once the adhesive has fully cured, torque nut(s) to the approved adhesive manufacturing specification.

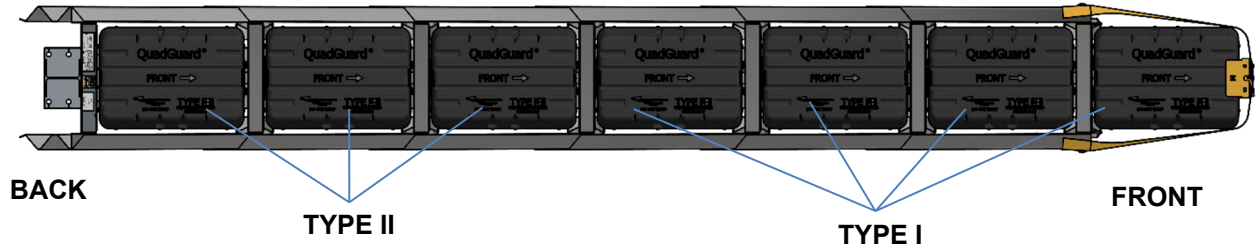


Figure 11 Plan View

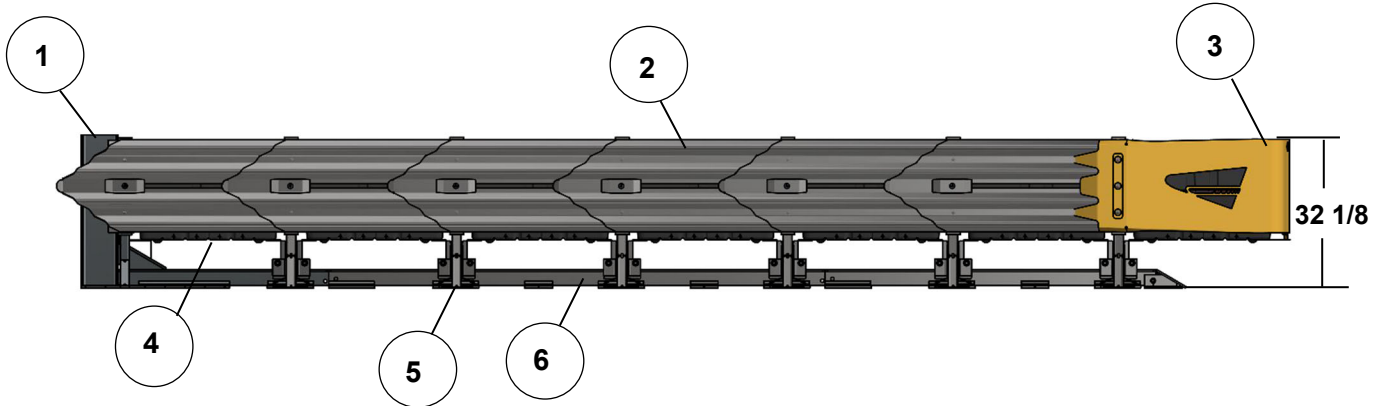


Figure 12 Elevation View  
6 Bay TL-3

**KEY**

- 1) Backup
- 2) Quad-Beam Fender Panel
- 3) Nose Cover
- 4) Cartridge
- 5) Diaphragm
- 6) Monorail

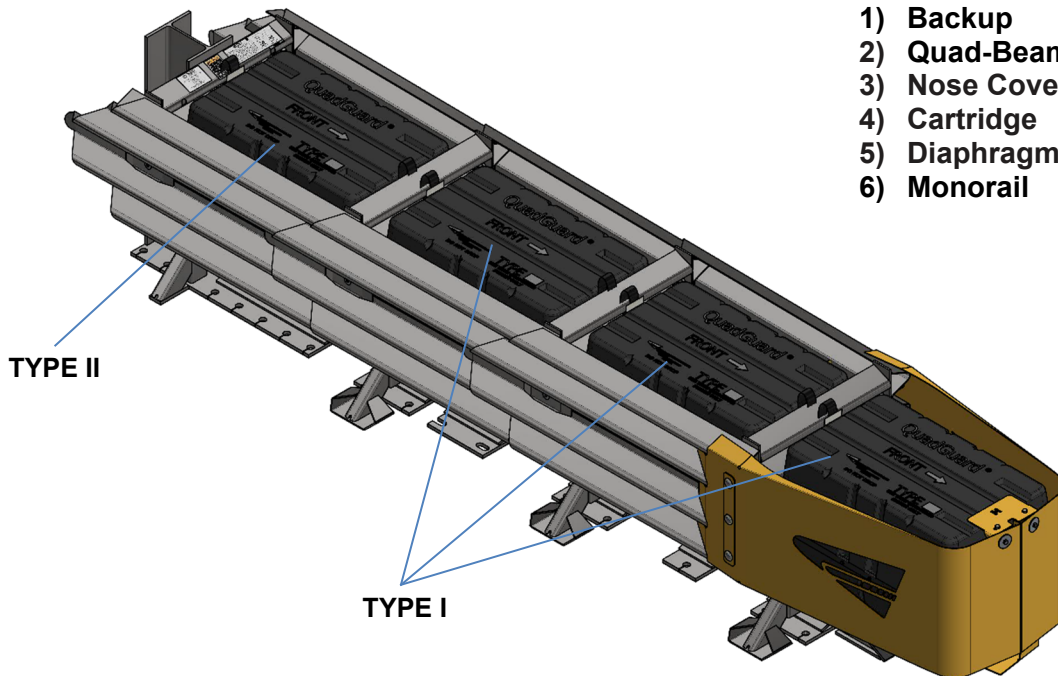


Figure 13  
3 Bay TL-2

## How to Determine Left/Right

To determine left from right when ordering parts, stand in front of the system facing the roadside obstacle. Your left is the system's left and your right is the system's right.

## Counting the Number of Bays

One Bay consists of one Cartridge, one Diaphragm, and two Fender Panels. The Nose section is not considered a Bay, though there is a Cartridge in the Nose of each system.

**Note:** There will always be one more Cartridge in the system than the number of Bays in the system. To determine number of Bays, count Fender Panels on one side (Figure 14).

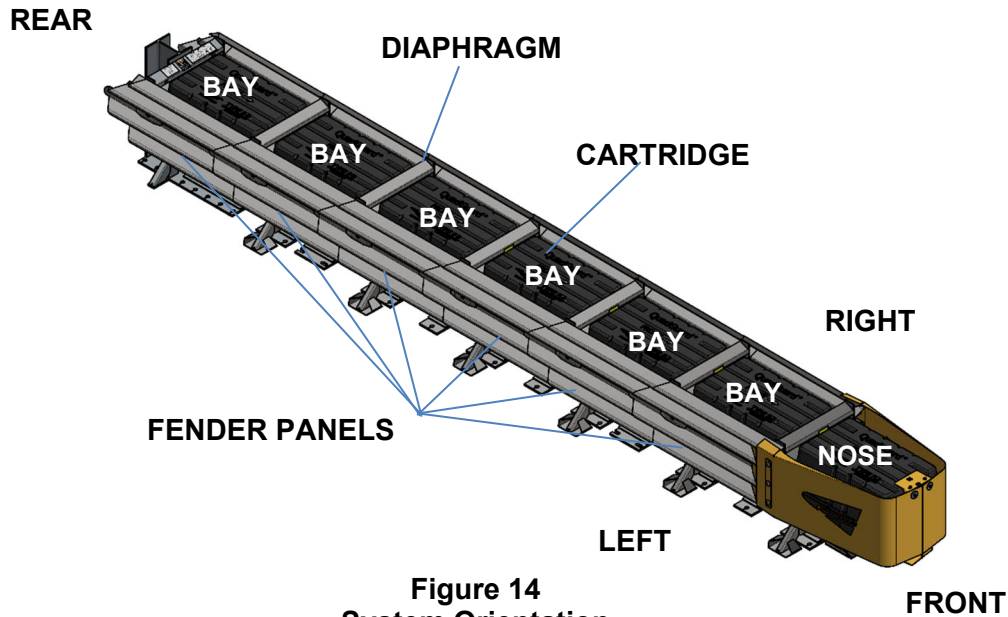


Figure 14  
System Orientation

## Measuring the Width

The nominal width of the 24" parallel system is the width of the diaphragm (Figure 15).

The outside width of the system is approximately 6" [152 mm] wider than the nominal width.

**Note:** The outside width of the system is not the same as the width of the Backup.

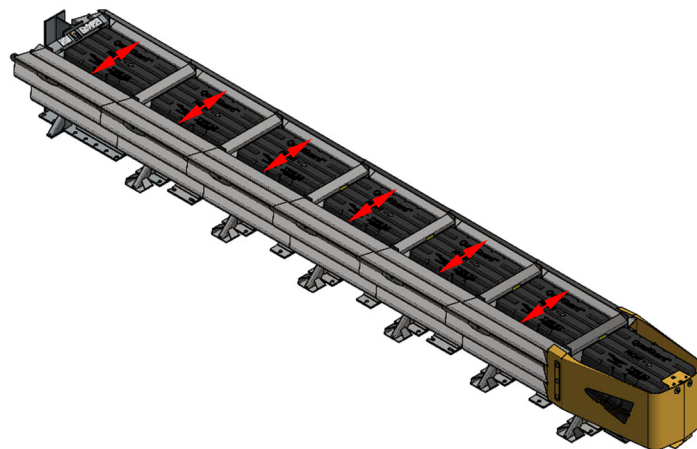


Figure 15  
Width of Parallel system

## System Assembly



**Warning:** It is the responsibility of the installer to ensure the assembly procedure meets all appropriate OSHA and local standards.

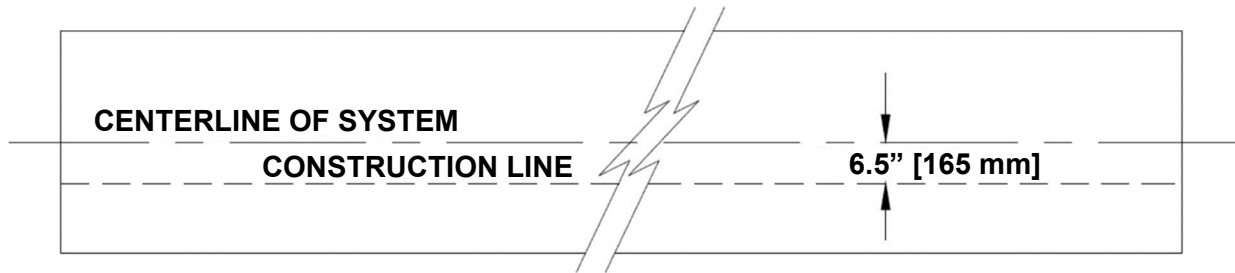
### 1) Mark System Location

Locate the centerline of the system by measuring the proper offset from the fixed object. Refer to the Drawing Package supplied with the system. Place chalk line to mark the centerline of the system. Mark a construction line parallel to the center line and offset 6.5" [165 mm] to one side as shown in Figure 16. The edge of the Monorail will be positioned on this line.

**Note:** The concrete foundation must comply with the Manufacturer's Drawing Package supplied with the system.



**Warning:** Location of system with respect to the roadside obstacle is critical and dependent on the type of Transition Panel used. Please refer to the Drawing Package supplied with the system for details.



**Figure 16**  
(Top view of concrete foundation)

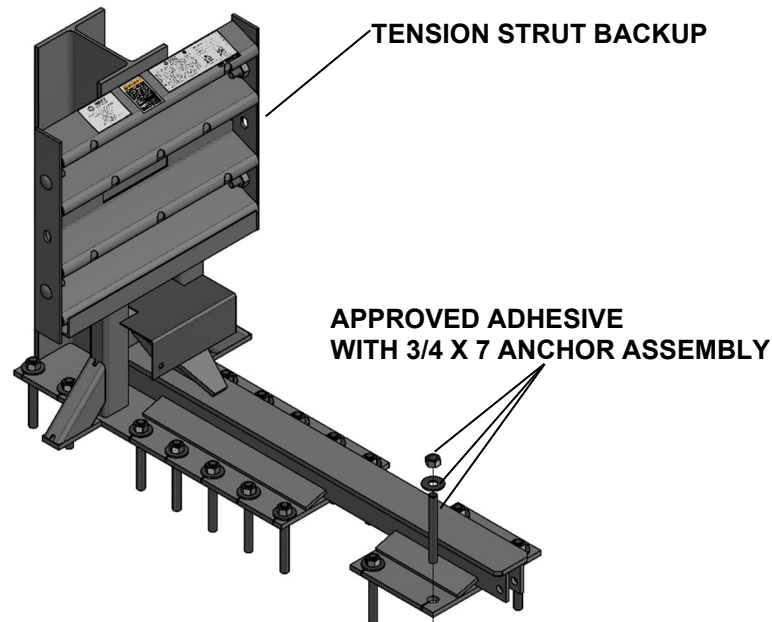
## 2) Anchor the Tension Strut Backup (Figure 17)

Locate Tension Strut Backup and Monorail on foundation with side of Monorail on the construction line (p. 24). **Verify that any applicable Transition Panels fit properly before anchoring Backup.** Drill 7/8" [22 mm] diameter by 5 3/4" [145 mm] anchor boreholes in foundation using the Backup as template. Anchor the Backup to the concrete foundation using an approved adhesive supplied with the QuadGuard® M10 (p. 16).

**Note:** Verify that any applicable Transition Panels fit properly before anchoring Backup.



**Caution:** Every hole in the Backup and Monorail must be anchored by a stud using an approved adhesive (p. 16).



**Figure 17**  
**Anchoring Tension Strut Backup to Foundation**

## 3) Anchor the Monorail

### Monorail Placement for Tension Strut Backup (Figure 21)

Locate Monorail on foundation with side of Monorail on the construction line and rear edge of Backup foot 4" forward of edge of foundation.

Orient the Monorail so that the Monorail tongues face the Backup.



**Warning:** Improper alignment at the Monorail splice joints may prevent proper system collapse during an impact (p. 24, Detail 19a).

It is important to align each segment of Monorail from the back to the front of the system ( $\pm 1/4$ " [6 mm]). Anchor each Monorail section using the Valtir approved adhesive kits provided (p. 16).

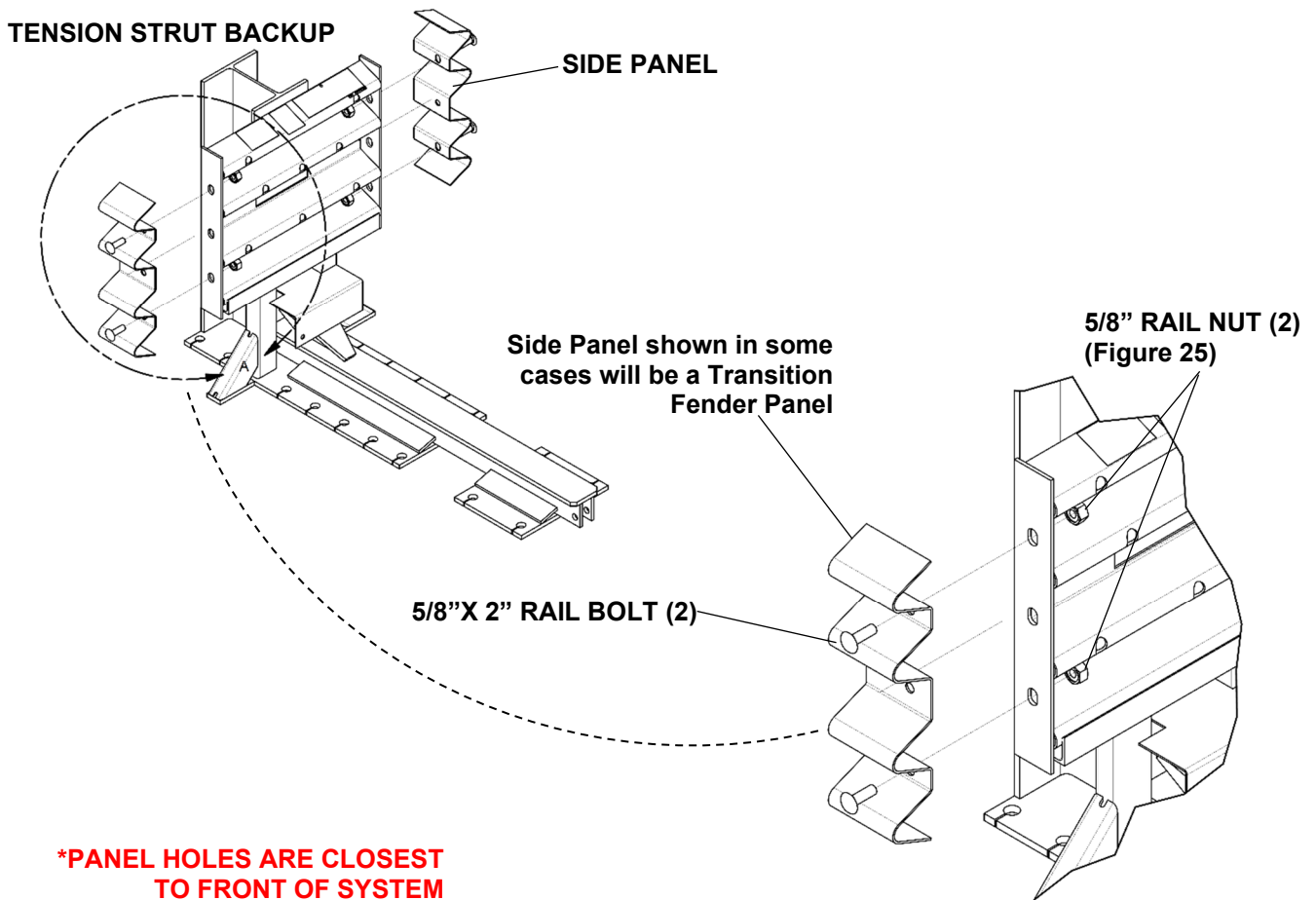
#### 4) Attach Side Panels and/or Transition Panels to Backup Assembly

Attach Transition Panel or Side Panel to side of Backup using 5/8" rail bolt and 5/8" rail nut (two places - top and bottom holes only\*). See Backup Assembly drawing(s) **below**.

**Note:** Do not use a Side Panel when a Transition Panel is used.

#### **Assembly Tip:**

Use drift pin to align the center hole of the Side Panel with the center hole of the Backup before inserting the Rail Bolts.



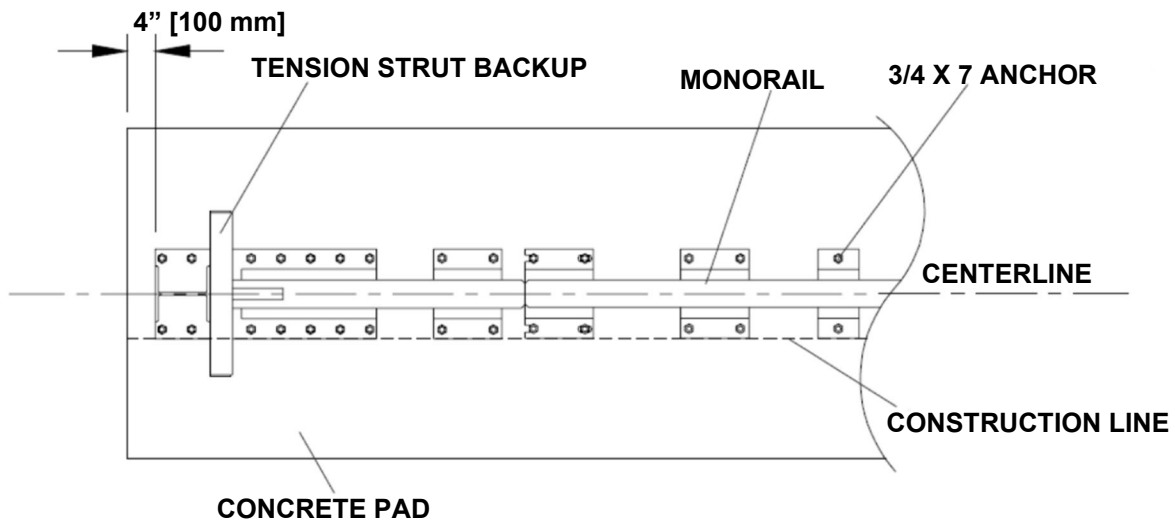
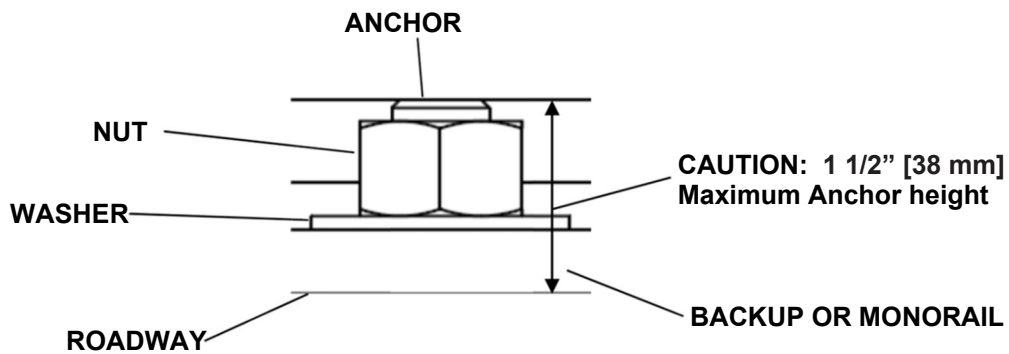
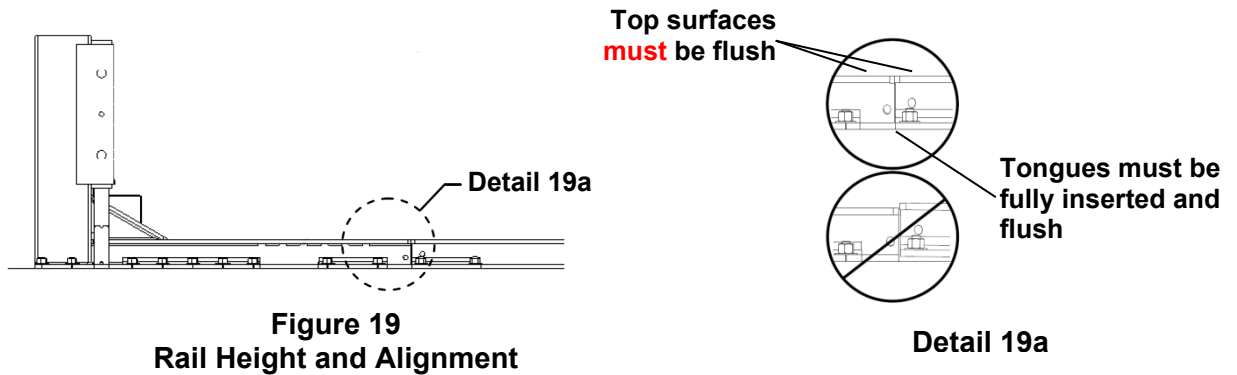
**Figure 18**  
Side Panel/Transition Panel Attachment





**Warning:** Every hole in the Backup and Monorail must be anchored by a stud using an approved adhesive (p. 16).

Drill 7/8" [22 mm] diameter by 5 3/4" [145 mm] boreholes using the Monorail as a template. Do not drill through foundation.



## 5) Attach Monorail Guides

Attach Monorail guides to Diaphragm as follows:

Insert 3/4" x 2" G8 hex bolt through Monorail guide and Diaphragm with a shim placed between them and oriented as shown in Figure 22. Secure with 3/4" lock washer and 3/4" hex nut (typical 4 places). See the Diaphragm Assembly drawing supplied with the system.

Repeat process for each Diaphragm.

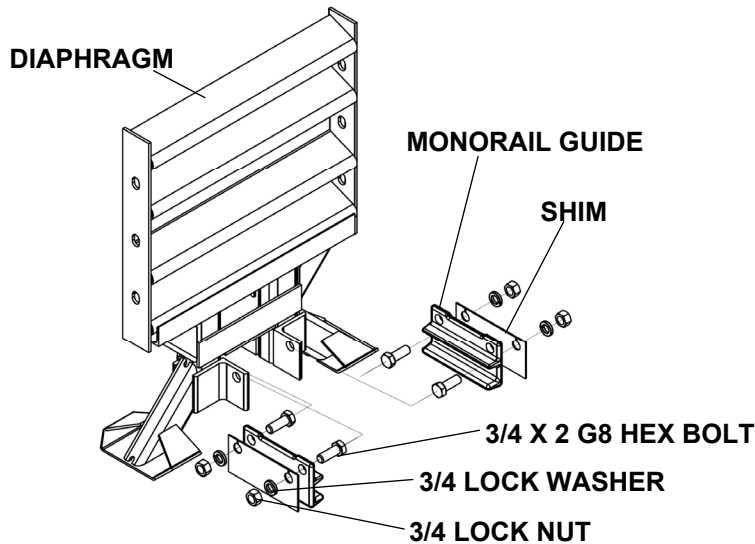
## 6) Attach Diaphragms

Orient a Diaphragm so that the front face of the Diaphragm shape faces toward the Nose of the system as shown in Figure 23.

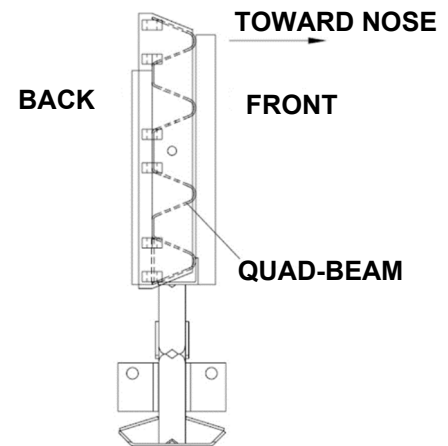


**Important:** Slide one Diaphragm all the way to the Backup to ensure the system is able to collapse properly during impact.

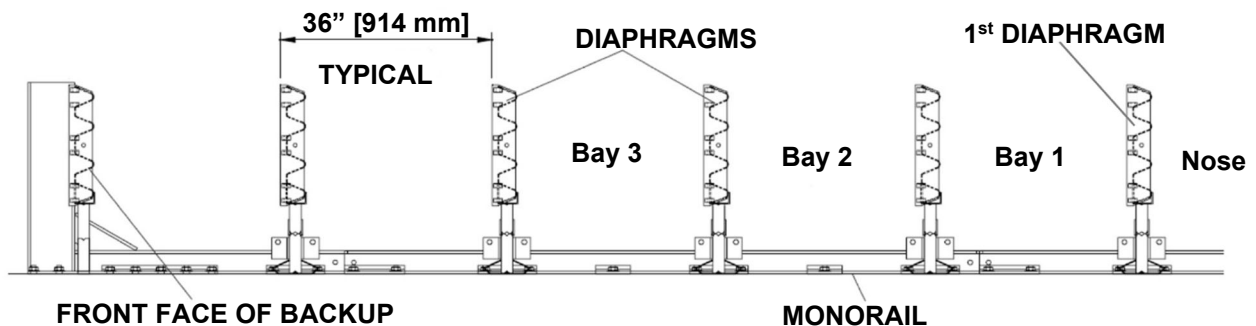
Orient and slide all other Diaphragms onto Monorail and position each approximately as shown in Figure 24.



**Figure 22**  
**Monorail Guide Attachment**



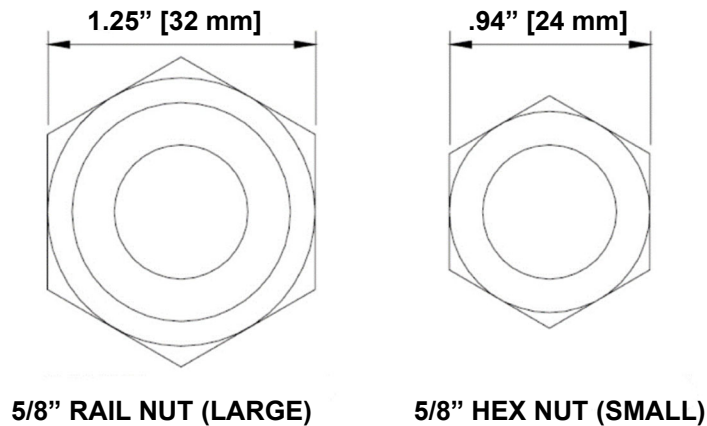
**Figure 23**  
**Diaphragm Orientation**



**Figure 24**  
**Diaphragm Spacing**

## 7) Attach Fender Panels

**Note:** Do not mix the 5/8" rail nuts (large) with the 5/8" hex nuts (small) (Figure 25).



**Figure 25**  
**Rail Nuts are Oversize**

**Note:** Starting at the Backup, attach left and right Fender Panels shown below in Step(s) 4 & 5 with each tapered end pointing toward the rear of the system (p. 27).

### Step 1

Place the Fender Panel so that the center of the slot of the rearward Diaphragm is lined up with the approximate center of the slot in the Fender Panel.

Attach Mushroom Washer Assembly as shown in Figure 26, Detail 26a, and 26b. Do not torque fasteners at this time. This (Step 1) helps to balance the Fender Panel.

### Step 2

Slide the Fender Panel forward until the holes in the Fender Panel line up with the holes in the forward Diaphragm.

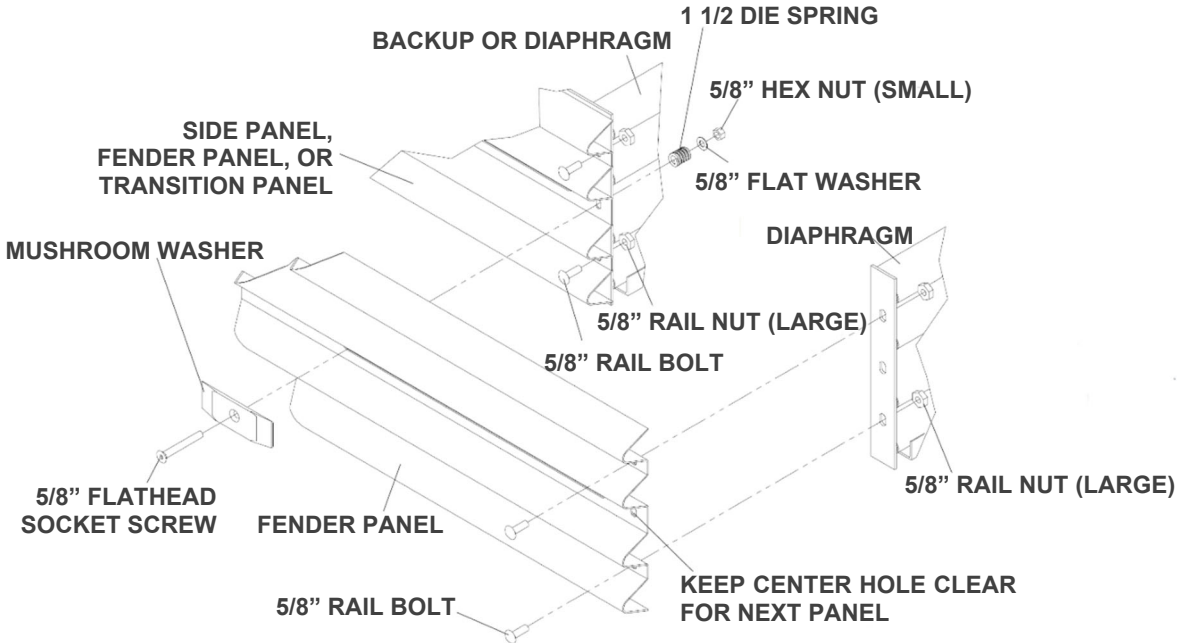
### Step 3

Use a drift pin to align the center hole of the Fender Panel with the center hole of the Diaphragm.

**Note:** Working from the Backup, assemble and tighten each Bay section one at a time toward the Nose of the system.

**Step 4**

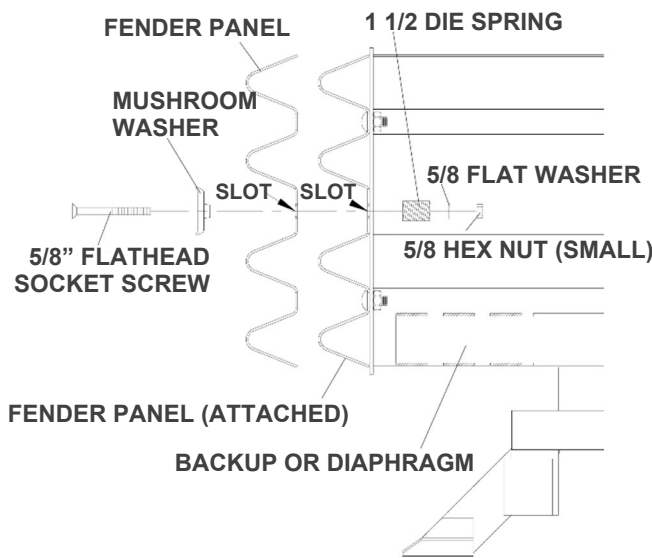
Attach the front of the Fender Panels to the next Diaphragm using two (2) rail bolts and large hex nuts per side. Use only the top and bottom holes and leave the center hole open until the next Fender Panel is attached.



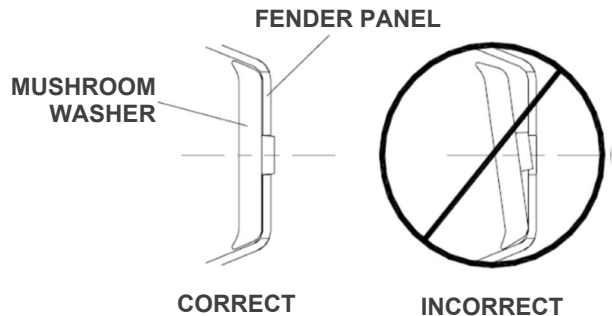
**Figure 26  
Fender Panel Assembly**

**Step 5**

Be sure Mushroom Washer lays flat against the Fender Panel as shown in Detail 26b. Standoff on Mushroom Washer must be seated completely through slot.



**Detail 26a  
Mushroom Washer Attachment**



**Detail 26b  
Mushroom Washer Orientation**



**Important:** Starting from the Backup, attach and tighten each Bay section one at a time.

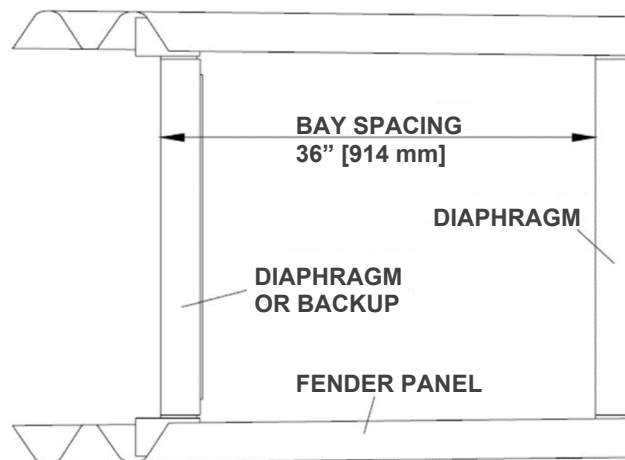
### **Step 6**

Check Diaphragm spacing to ensure 36" [914 mm] between rear faces of consecutive Diaphragms as shown in Fender Panel assembly drawing (Figure 27).

### **Step 7**

Once proper spacing has been achieved, tighten the Mushroom Washer Assembly (small hex) nut until it reaches the end of the threads.

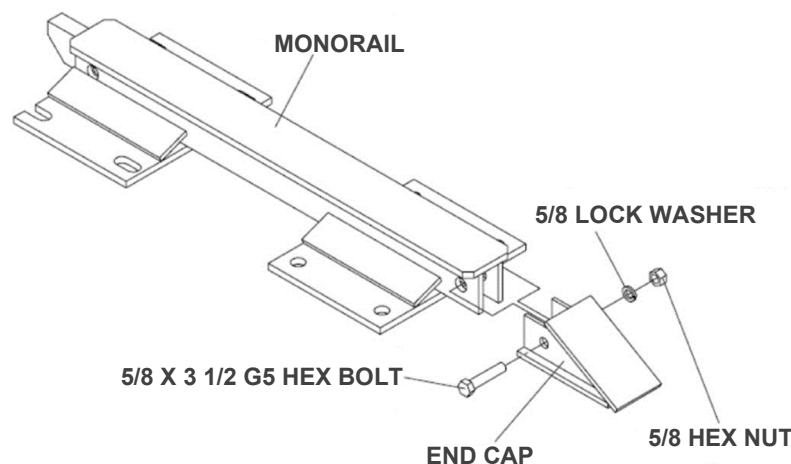
Assemble the remaining Diaphragms and Fender Panels following the same procedures.



**Figure 27**  
**Proper Diaphragm Spacing**

### **8) Attach End Cap**

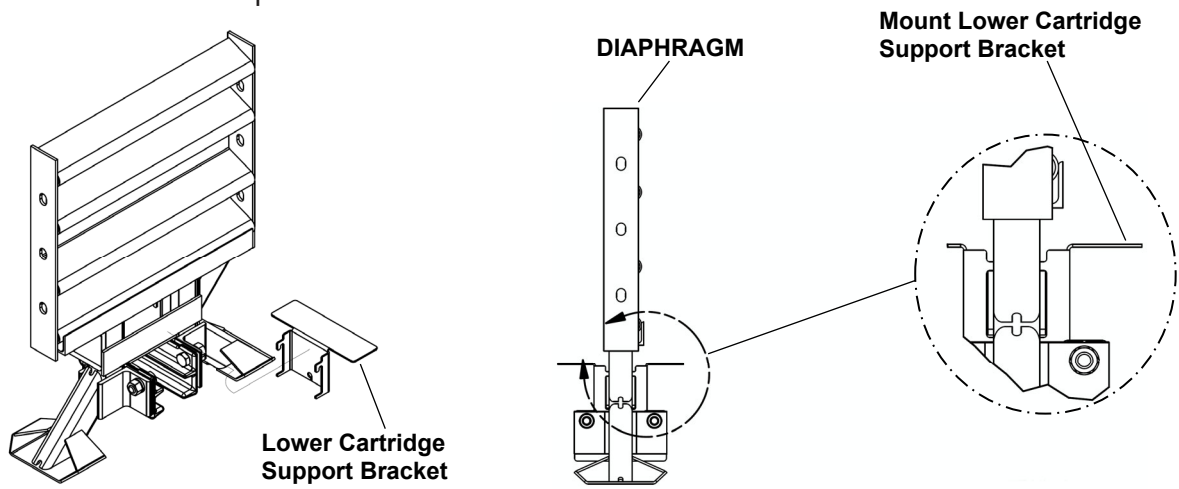
Attach the End Cap to the front of the first Monorail segment, as shown below and the Monorail Assembly drawing.



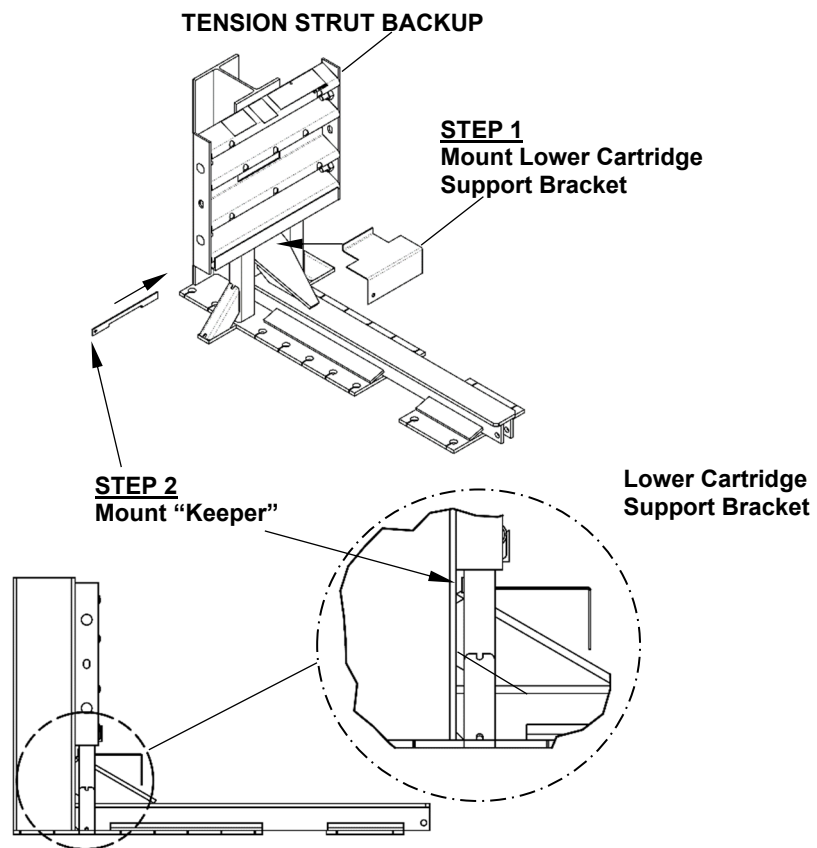
**Figure 28**  
**Monorail End Cap Attachment**

9) **Attach Lower Cartridge Support Brackets**

Attach lower Cartridge Support Bracket to the front and back of all Diaphragms and also to the front of the Backup as shown below.

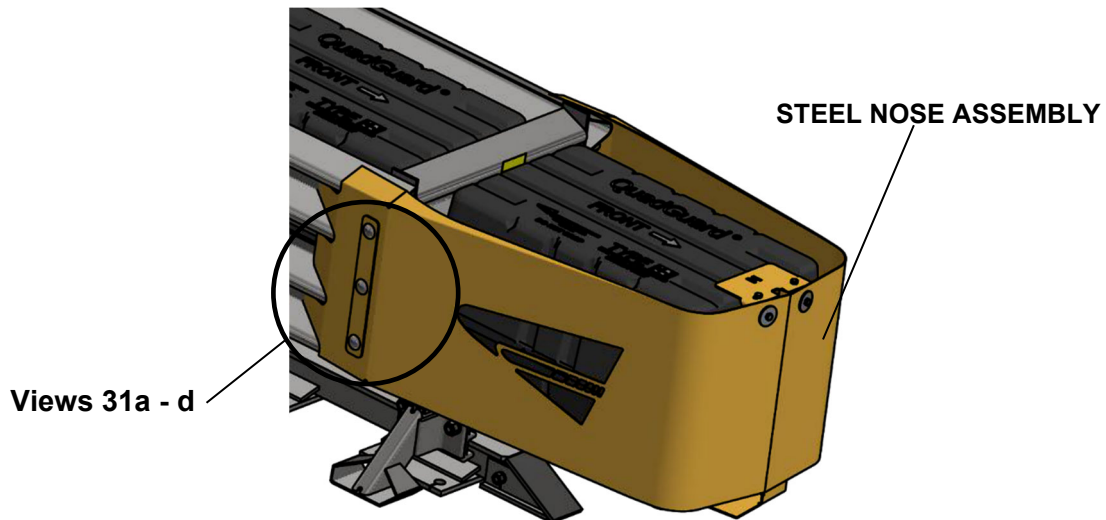


**Figure 29**  
**Lower Cartridge Support Bracket Assembly**



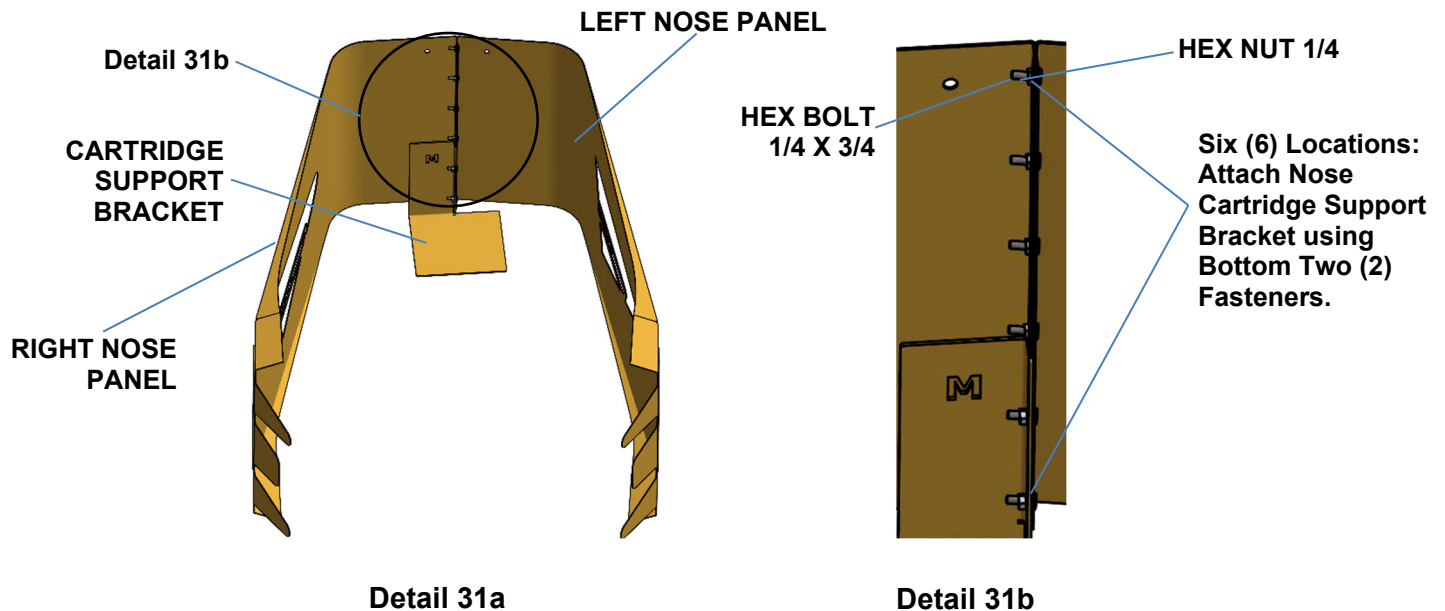
**Figure 30**  
**Lower Cartridge Support Bracket Assembly**  
**(Tension Strut Backup)**

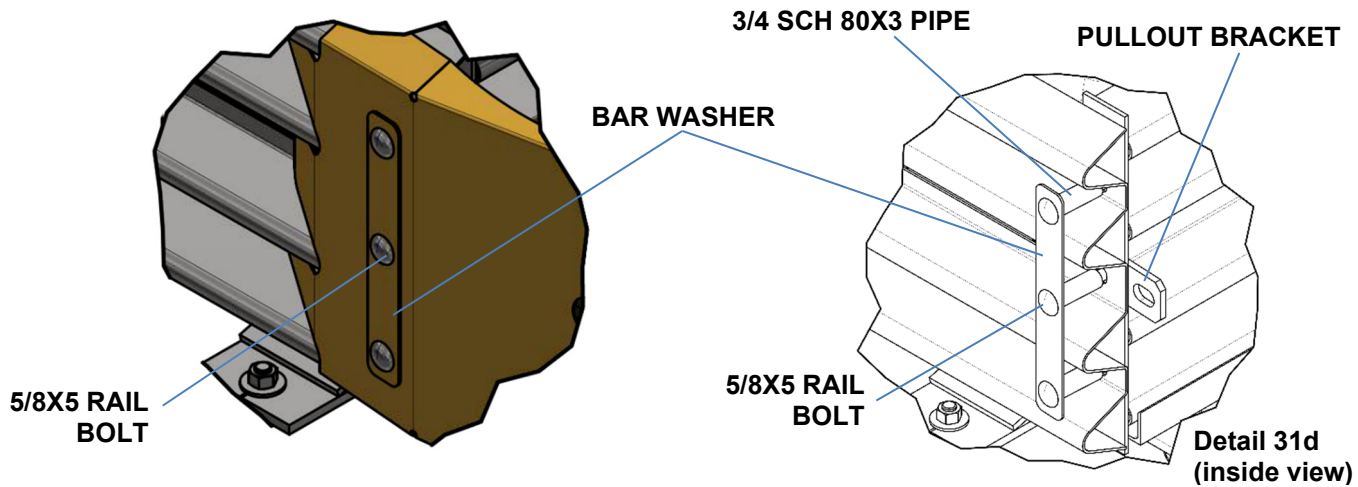
10) Nose Assembly



**Figure 31  
NOSE ASSEMBLY (p. 47)**

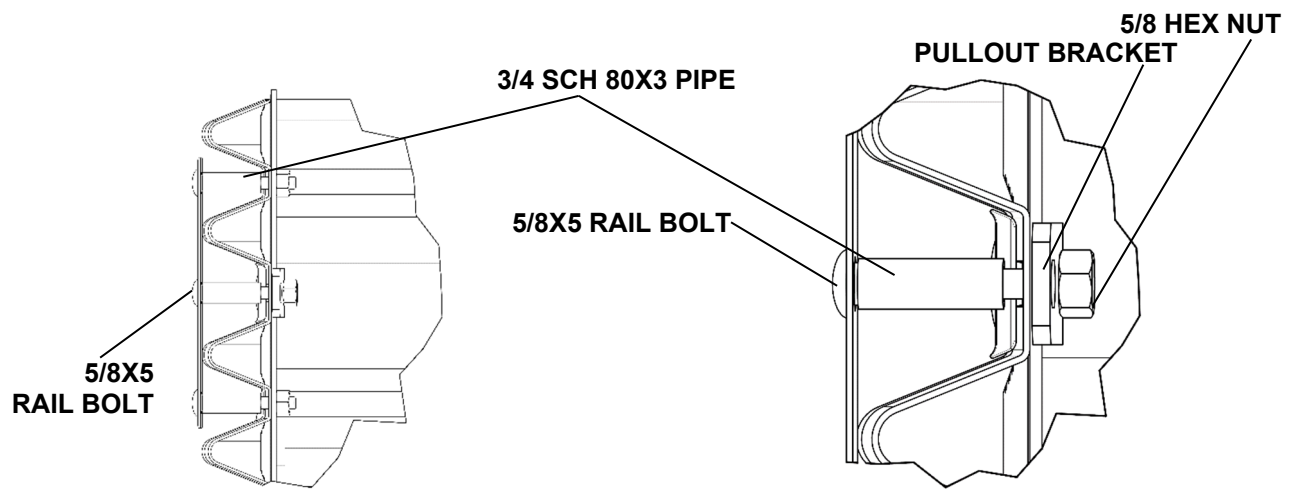
- A. Preassemble Left and Right Nose Panels and Cartridge Nose Support Bracket using 1/4X3/4 hex bolt and hex nuts (Detail 31a & 31b).
- B. Attach preassembled Nose Assembly to front Diaphragm with 5/8X5 rail bolts, bar washers, 3/4 sch 80X3" pipe, pullout brackets and 5/8 hex nuts. Do not tighten at this time (Details 31c, 31d, 31e).
- C. Adjust Nose assembly height so top front Nose is 32 1/8 above concrete pad. Tighten all six (6) rail bolts and nuts.
- D. Install Type 1 Cartridge insuring directional arrow is pointing to front of system.
- E. Assemble QuadGuard® M Cartridge Hold Down Bracket with 3/8X1 hex bolts, washers and nuts (Figure 32).





**Detail 31c**  
Fastener Assembly

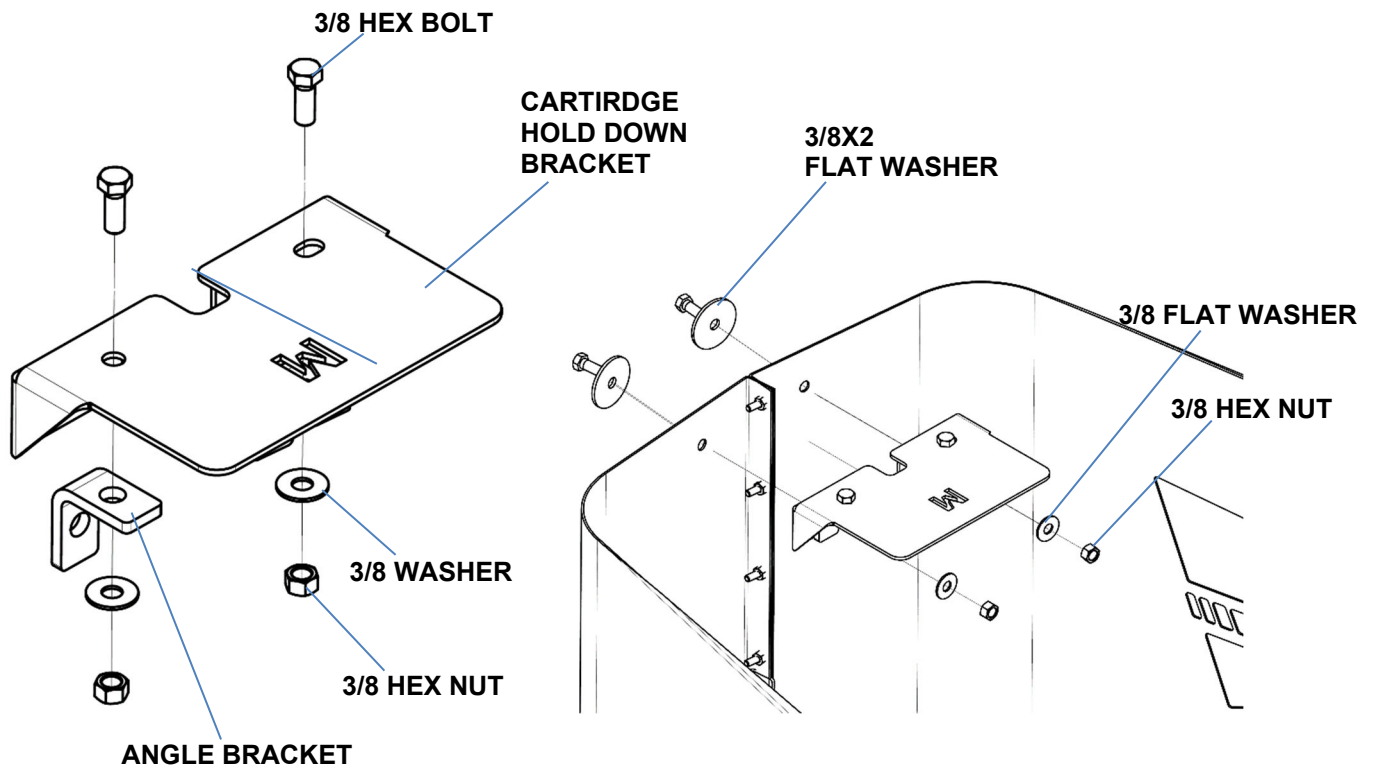
**Detail 31d**  
Steel Nose not shown for clarity



**Detail 31e**  
End View: Nose Cover Removed

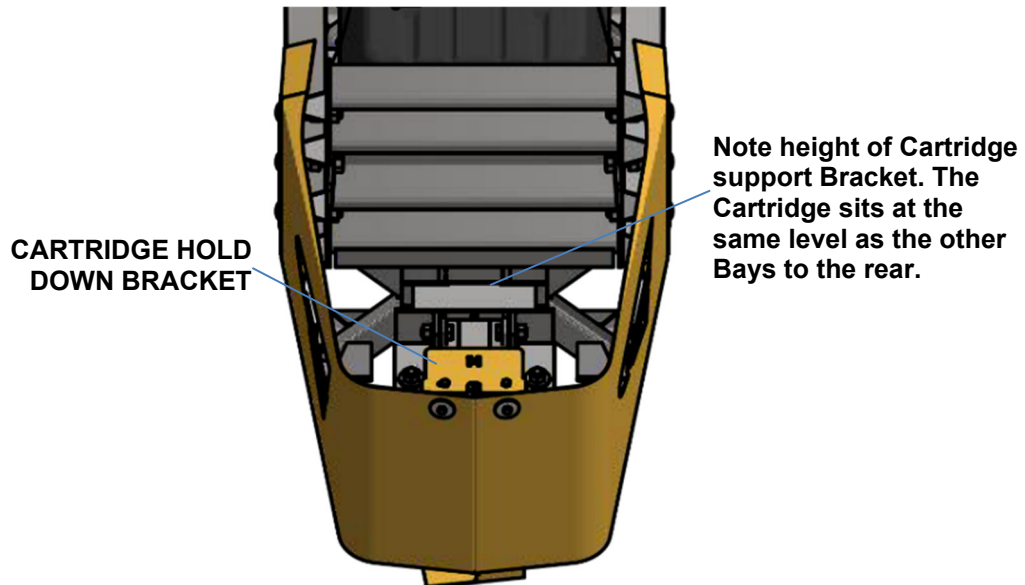
**Detail 31f**  
Inside View: Nose Cover Cut Away





**Figure 32**  
**Hold Down Bracket Assembly**

**Note: Figure 33 shows proper placement of Cartridge Nose Support Bracket.**



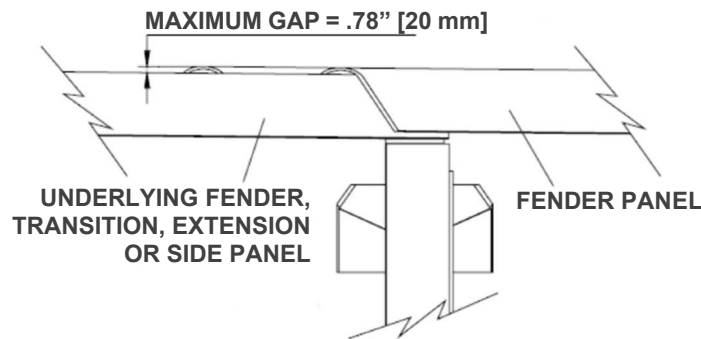
**Figure 33**

### 11) Checking the System Assembly

At this point recheck to ensure that all fasteners are properly tightened throughout the system (anchor bolts, etc.). See torque requirements below. Check all Fender Panels. If they do not fit tightly against the underlying Panel, system realignment may be necessary (Figure 34).



Warning	
Bolt Torque Requirements	
Anchor Studs – p. 16	
Critical Clearances	
Anchor Studs above nuts – p. 24, Figure 20	
Fender Panel Gap – .78" [20 mm] Figure 34	



**Figure 34**  
**Fender Panel Gap**

### 12) Cartridge Placement

The top surface of the Nose Cartridge should be horizontal. To complete the assembly of a QuadGuard® M10, place the appropriate Cartridge in each Bay and Nose section of the system. Type I Cartridges are placed toward the front (Nose) of the system; Type II Cartridges are placed toward the rear (Backup) of the system (p. 19).



**Warning:** Placing the wrong Cartridge in the Nose or Bay(s) could result in unacceptable crash performance per MASH criteria and cause serious injury or death to occupants and/or bystanders in the event of a vehicle impact.



**Important:** The QuadGuard® M10 is a six (6) Bay configuration.

## **QuadGuard® M10 24” Final Inspection Checklist**

Site Location: \_\_\_\_\_

Date: \_\_\_\_\_

Inspector: \_\_\_\_\_

**Refer to the QuadGuard® M10 24” manual and / or drawing package.**

- Transition Panel fits for the offset (p. 11)
- Clearance of 30” behind rear Fender Panels for slide back (p. 14)
- Anchor nuts are torqued to manufacturer specification (p. 16)
- Top of Nose panels are 32 1/8” above concrete pad (p. 19)
- Cartridges are level and the same height in each Bay (p. 19)
- Correct Cartridge is placed in each Bay and pointing to front of system (p. 19)
- Cartridge Hold Down Bracket is secure and engaged with Nose Cartridge (p. 19)
- Every hole and slot in Backup and Monorail is anchored (pp. 22, 24)
- If no transition, check for narrow side panels at backup (p. 23)
- Anchor stud(s) are 1.5” maximum above the pad) (p. 24)
- Diaphragms attached to the Monorail guides (p. 25)
- Diaphragm Shims installed between Diaphragm & Monorail guides (p. 25)
- Each Fender Panel has a tension Die Spring (p. 27)
- Mushroom Washers lay flat in slots (p. 27)
- Monorail has End Cap attached (p. 28)
- Nose Cartridge is at the same height as Bay Cartridges (p. 30)
- Fender Panel gap is .78” [20 mm] for Narrow systems (p. 33)
- Bolts and nuts are properly tightened (p. 33)
- System is clear of debris

## **Maintenance and Repair**

### **Inspection Frequency**

Inspections for QuadGuard® M10 are recommended as needed based upon volume of traffic and impact history. Visual Drive-By Inspections are recommended at least once a month. Walk-Up Inspections are recommended at least once a year.

### **Visual Drive-By Inspection**

- 1) Check to see if there is evidence of an impact. If so, perform a walk-up inspection.
- 2) Check to see if the Cartridges are properly seated on the Support Brackets. Any damaged Cartridges must be replaced.



**Warning:** See Cartridge placement instructions on page 19.

- 3) Be sure the Steel Nose is in place.
- 4) Note the location and condition of the QuadGuard® M10 and the date of visual drive-by inspection.

### **Walk-Up Inspection Checklist**

- Clear and dispose of on-site debris.
- Clear and remove excessive dirt from around the Monorail and Diaphragm feet.
- Bolts are tight and rust free.
- Anchor bolts are securely anchored.
- Diaphragm Legs are straight.
- All Mushroom Washer Assemblies are properly seated.
- Fender Panels and Transition Panels should nest tightly against the system.
- Cartridges have not been damaged and are properly seated on their Support Brackets. To ensure intended speed characteristics, partially crushed Cartridges (due to low speed impacts) must be replaced.
- Make all necessary repairs as described above. See Post-Impact Instructions for more information on next page.
- To determine if a product should be replaced or is potentially reusable, a trained engineer experienced in highway products and directed by the DOT, or other appropriate local highway authority, must be consulted.

## Post-Impact Instructions



**Important:** Valtir makes no recommendation whether use or reuse of any part of the system is appropriate or acceptable following an impact. It is the sole responsibility of the local highway authority and its engineers to make that determination. It is critical that you inspect this product after assembly is complete to make certain that the instructions provided in this manual have been strictly followed.

- 1) Deploy appropriate traffic-control devices.
- 2) Ensure all anchor bolts have remained firmly anchored in the roadway surface. Replace any loose, broken, or pulled out anchors.

**The performance of the system during an angle impact depends on a properly anchored Monorail.**

- 3) Clear and dispose of any debris on site.
- 4) Ensure the Mushroom Washer Assemblies are intact so the system can be restored to its original position.

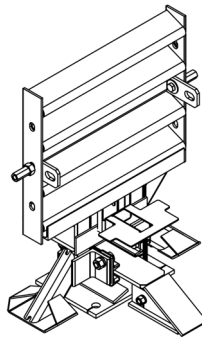


**Caution:** Use eye protection and gloves when refurbishing the Mushroom Washer Die Spring Assembly. Do not place fingers underneath an assembled Mushroom Washer. Parts may suddenly shift and fingers may be pinched. If the Die Spring is still under compression as the nut is nearing the end of the bolt, to prevent injury make sure that the Die Spring is restrained with a clamp so it does not suddenly release when the nut is removed from the Mushroom Washer Bolt.

- 5) The Diaphragm Support Legs are all properly attached to the Monorail.
- 6) Remove the Nose Assembly and attach a chain to the Pullout Brackets on the first Diaphragm (Figure 35). Attach both ends of chain to a heavy vehicle (such as a 1 ton pickup).



**Warning:** Stand clear in case chain breaks or becomes disconnected.



**Figure 35**  
**Pullout Brackets**



**Important:** Slowly pull the system forward to its original length. Have someone watch the repositioning to ensure undetected damage does not cause the Diaphragms to bind or pull out improperly.

- 7) Remove all crushed Cartridges.
- 8) All Diaphragms are in usable condition. Diaphragms which are bowed or have bent legs must be replaced.
- 9) Each Fender Panel is properly attached with Mushroom Washer Assemblies. Damaged Fender and Transition Panels must be replaced.

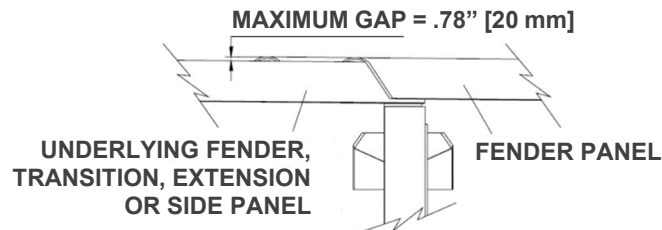


<b>Warning</b>	
<b>Anchor Torque and Clearance Requirements</b>	
Torque Requirements – Adhesive Manufacturer Spec Anchor clearance above nuts – Figure 20, p. 24	
<b>Fender Panel Critical Clearances</b>	
Fender Panel Gap– .78" [20 mm]	

- 10) Check the **gaps between Fender Panels**. The maximum gap allowed for these overlapping parts (including Fender Panels overlapping Panels behind the system) is .78" [20 mm].



**Important:** Ensure the Mushroom Washer Assemblies are torqued to the end of the threads. If the gaps between the Fender Panels are still too large, it may be necessary to replace bent parts.



**Figure 36**  
**Fender Panel Gap**

- 11) Replace all crushed Cartridges and damaged Cartridge Support Brackets. See Cartridge Placement on page 19.
- 12) Remove damaged Nose Assembly. Attach the new Nose to the first Diaphragm. See pages 30 - 32 and 47 for Nose attachment instructions.
- 13) All bolts on the system are adequately tight.
- 14) Site is free from debris.
- 15) The QuadGuard® M10 is now ready for use.

## Parts Ordering Procedure & Drawings

Make a list of all damaged parts from the System Components section in this manual (p. 7 – 10). Answer the following questions in the spaces provided. This information is necessary to receive the proper parts.

QuadGuard® M10 Ordering Information Chart		
Description:	Choices	Fill in this section
<b>Transition Panel Type?</b>  Side Panel and Transition Panel Types are on page 11. Include Transition options for both sides if necessary. How to Determine Left/Right is on page 20.	<ul style="list-style-type: none"> <li>• Quad to W-Beam Guardrail</li> <li>• Quad to Thrie Beam Guardrail</li> <li>• Quad to Safety Shape Barrier</li> <li>• Quad to Single Slope Barrier</li> <li>• Quad to Vertical Concrete End Shoe</li> <li>• None</li> </ul>	

## Parts List(s) & Quantities

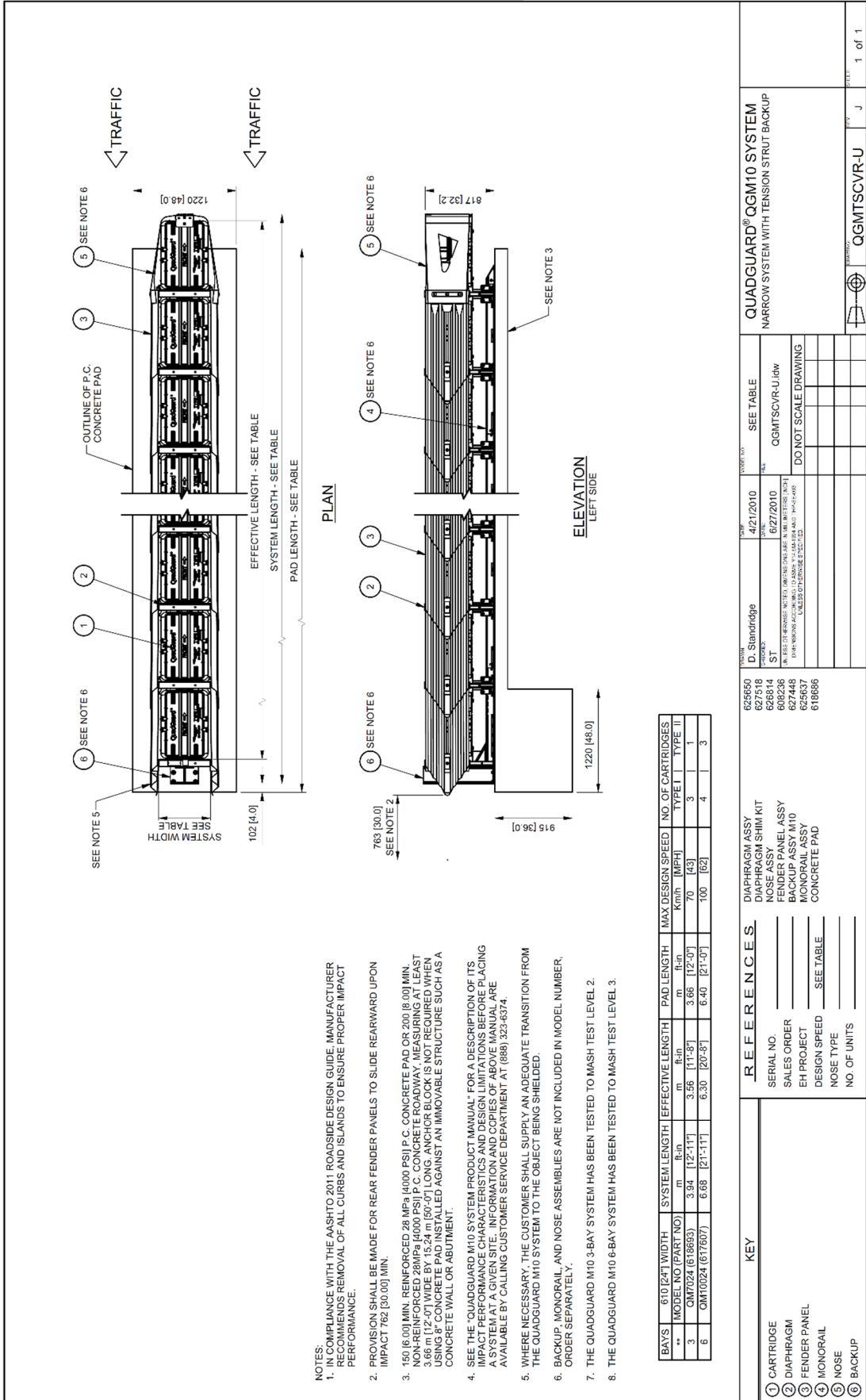
PN	Description	Tension Strut Backup	
		6 Bay	3 Bay
118710	Adhesive, HY200, 330, Hilti	14	9
626055	Backup, TS, 24, QG, M10, W/Decals	1	1
004441	Bolt, GR, 5/8X5, A307	6	6
113518	Bolt, Hex, 1/4X3/4, G5	6	6
113555	Bolt, Hex, 3/4X2, G8	24	12
113596	Bolt, Hex, 3/8X1, G5	4	4
113660	Bolt, Hex, 5/8X3 1/2, G5	1	1
003400	Bolt, Rail, 5/8X2	24	12
626817	Bracket, Angle, 2X1, W/Holes	2	2
626815	Bracket, Cart Hold Down, QG M	1	1
626816	Bracket, Cart Support, Nose, QG M	1	1
605446	Bracket, Cartridge Supt, Dia, Folded, QG	12	6
605447	Bracket, Cartridge, Supt, TS B/U, QG	1	1
605535	Bracket, Pull-Out, QG	2	2
625647	Diaphragm, QG, 24, QG	6	3
608136	Endcap, Monorail	1	1
611266	Locking Bar, Cartridge Supt, QG	1	1
611368	Monorail Guide, QG	12	6
611375	Monorail, 2 Bays	1	1

PN	Description	Tension Strut Backup	
		6 Bay	3 Bay
611379	Monorail, 3 Bays	1	0
611669	Nose, L, Narrow, QGII, W/Logo	1	1
611680	Nose, R, Narrow, QGII, W/Logo	1	1
003704	Nut, Hex Heavy, 3/4	80	48
003354	Nut, Hex Heavy, 5/8	13	7
115946	Nut, Hex, 1/4	6	6
115960	Nut, Hex, 3/8	4	4
003340	Nut, Hex, Rail, 5/8	34	22
611832	Panel, Fender, QG	12	6
611898	Panel, Side, QG	2	2
627537	Pipe, 3/4 Schedule 80X3	6	6
116878	Screw, FL Hex Socket, 5/8X5	12	6
614062	Shim, 12GA X 3 5/8X8	12	6
117459	Spring, Die, 1 1/4 OD X 1 1/2	12	6
117542	Stud, 3/4X7, G5	56	36
626818	Washer, Bar, 10GAX2X14	2	2
118036	Washer, Flat, 3/8X1, G	4	4
118038	Washer, Flat, 3/8X2	2	2
003300	Washer, Flat, 5/8X1 3/4	12	6
118027	Washer, Flat, Heavy, 3/4X2	56	36
118089	Washer, Lock, 3/4	24	12
118100	Washer, Lock, 5/8	1	1
617045	Washer, Mushroom Forged, QG	12	6



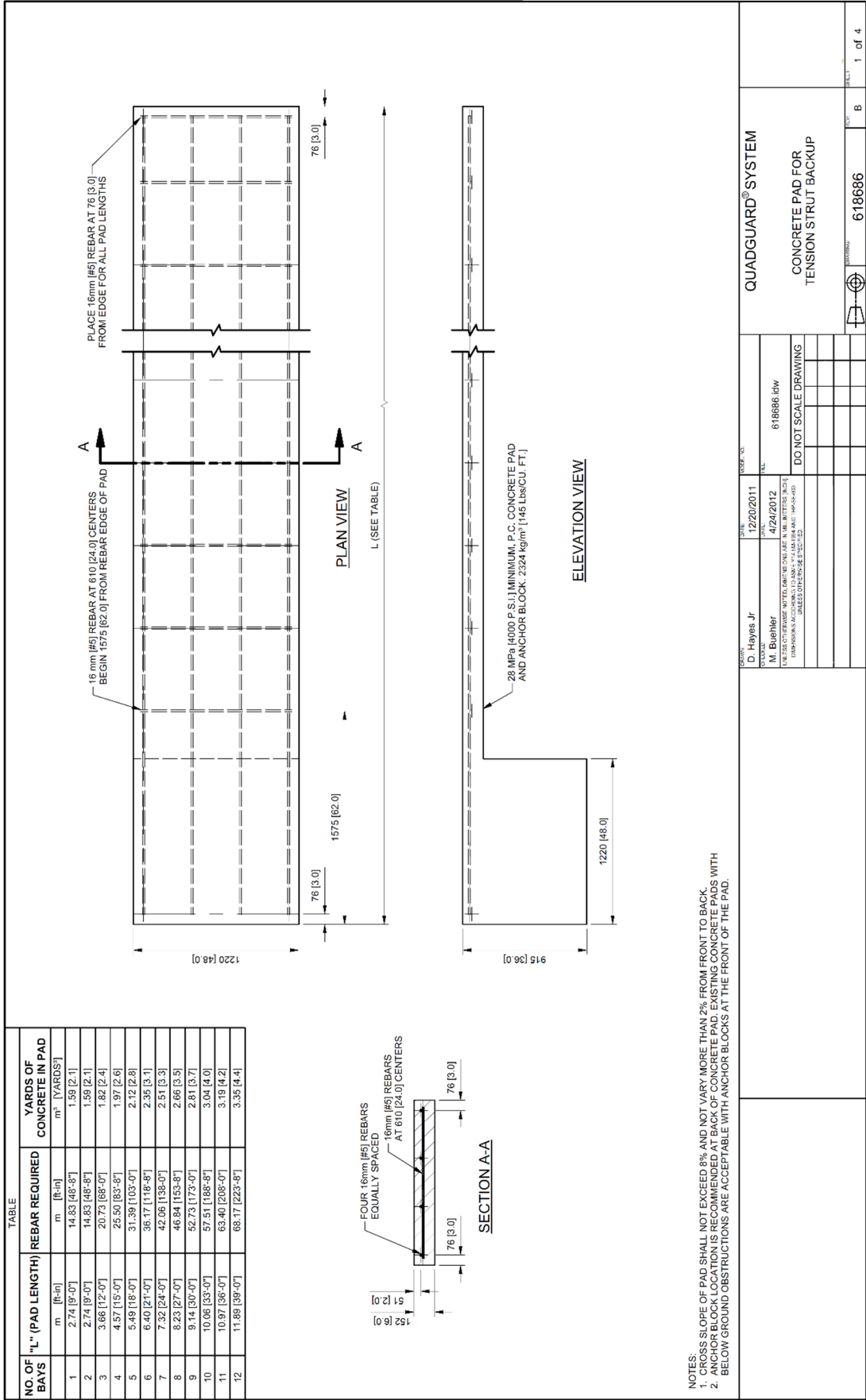
**Warning:** Use only Valtir parts that are specified herein for assembling, maintaining, or repairing the QuadGuard® M10. **Do not utilize or otherwise comingle parts from other systems even if those systems are other Valtir systems.** Such configurations have not been tested, nor have they been deemed eligible for use. Assembly, maintenance, or repairs using unspecified parts or accessories is strictly prohibited.





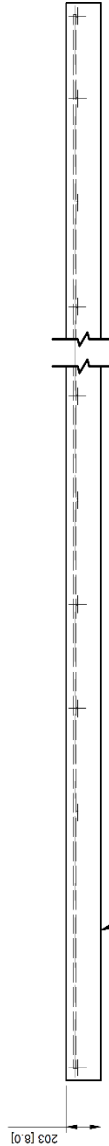
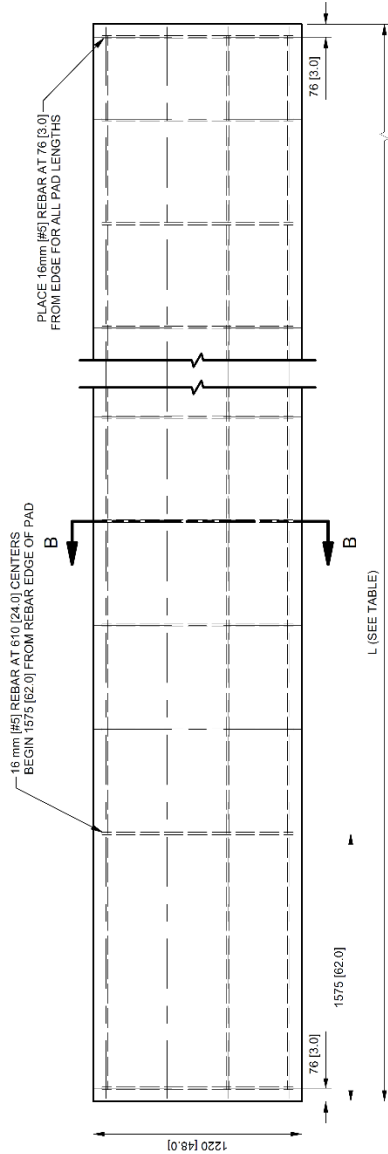
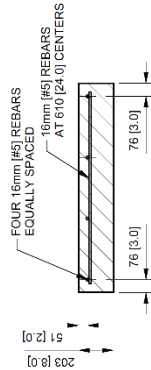
QuadGuard® M10 w/ Tension Strut Backup QGMTSCVR-U

1 of 1



**TS Concrete Pad 618686**

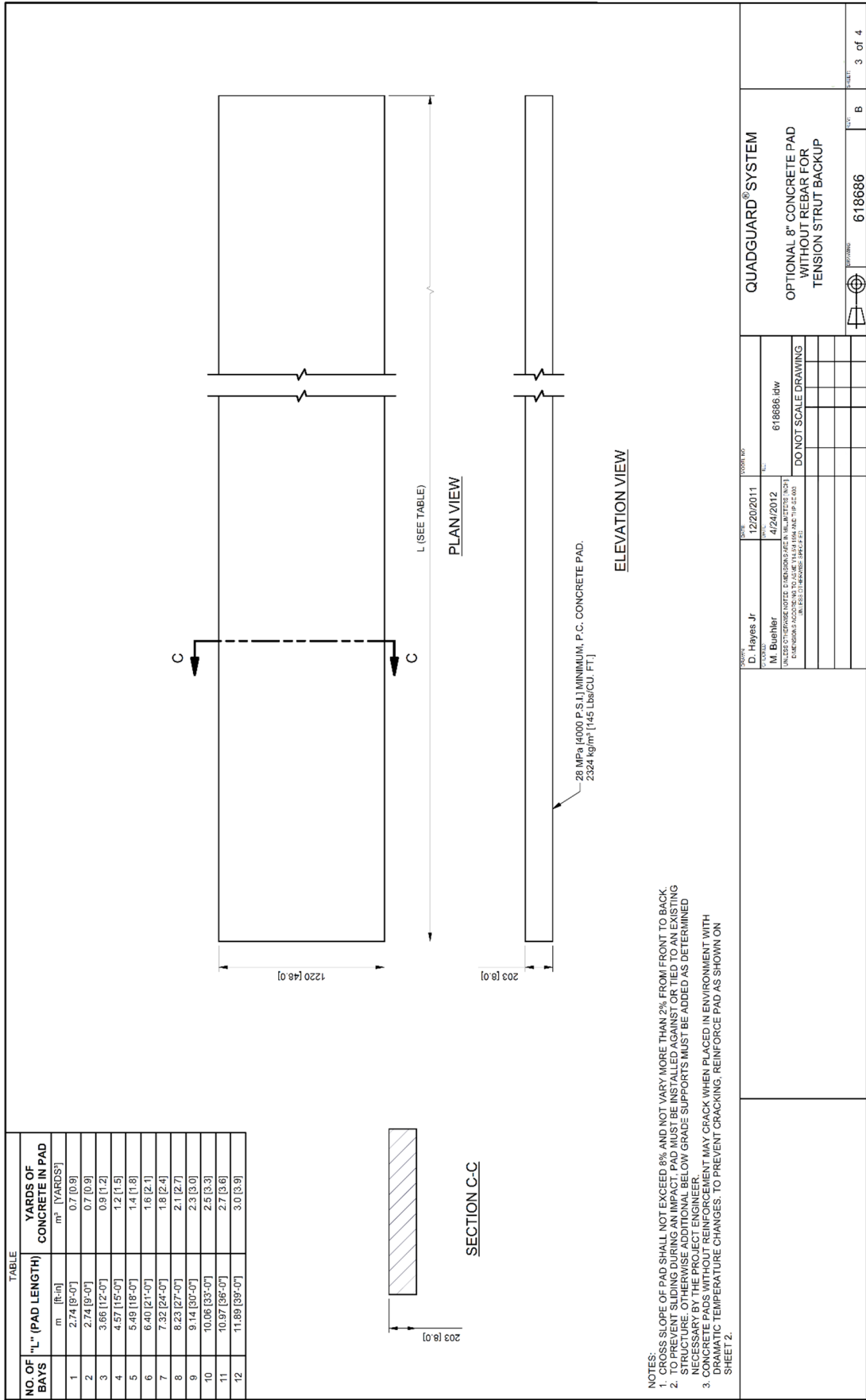
NO. OF BAYS	TABLE		YARDS OF CONCRETE IN PAD
	"L" (PAD LENGTH)	REBAR REQUIRED	
	m [ft-in]	m [ft-in]	m <sup>3</sup> [YARDS <sup>3</sup> ]
1	2.74 [9'-0"]	14.83 [48'-8"]	0.7 [0.9]
2	2.74 [9'-0"]	14.83 [48'-8"]	0.7 [0.9]
3	3.66 [12'-0"]	20.73 [68'-0"]	0.9 [1.2]
4	4.57 [15'-0"]	25.50 [83'-8"]	1.2 [1.5]
5	5.49 [18'-0"]	31.39 [103'-0"]	1.4 [1.8]
6	6.40 [21'-0"]	36.17 [118'-8"]	1.6 [2.1]
7	7.32 [24'-0"]	42.06 [138'-0"]	1.8 [2.4]
8	8.23 [27'-0"]	46.84 [153'-8"]	2.1 [2.7]
9	9.14 [30'-0"]	52.73 [173'-8"]	2.3 [3.0]
10	10.06 [33'-0"]	57.51 [188'-8"]	2.5 [3.3]
11	10.97 [36'-0"]	63.40 [208'-0"]	2.7 [3.6]
12	11.89 [39'-0"]	68.17 [223'-8"]	3.0 [3.9]



NOTES:  
 1. CROSS SLOPE OF PAD SHALL NOT EXCEED 8% AND NOT VARY MORE THAN 2% FROM FRONT TO BACK.  
 2. TO PREVENT SLIDING DURING AN IMPACT, PAD MUST BE INSTALLED AGAINST OR TIED TO AN EXISTING STRUCTURE. OTHERWISE ADDITIONAL BELOW GRADE SUPPORTS MUST BE ADDED AS DETERMINED NECESSARY BY THE PROJECT ENGINEER.

QUADGUARD <sup>®</sup> SYSTEM OPTIONAL 8" CONCRETE PAD WITH REBAR FOR TENSION STRUT BACKUP		PROJECT NO. 618686	SHEET 2 of 4
DESIGNER: D. Hayes Jr. DATE: 12/20/2011	CHECKER: M. Buehler DATE: 4/24/2012	FILE: 618686.dwg	
DO NOT SCALE DRAWING			

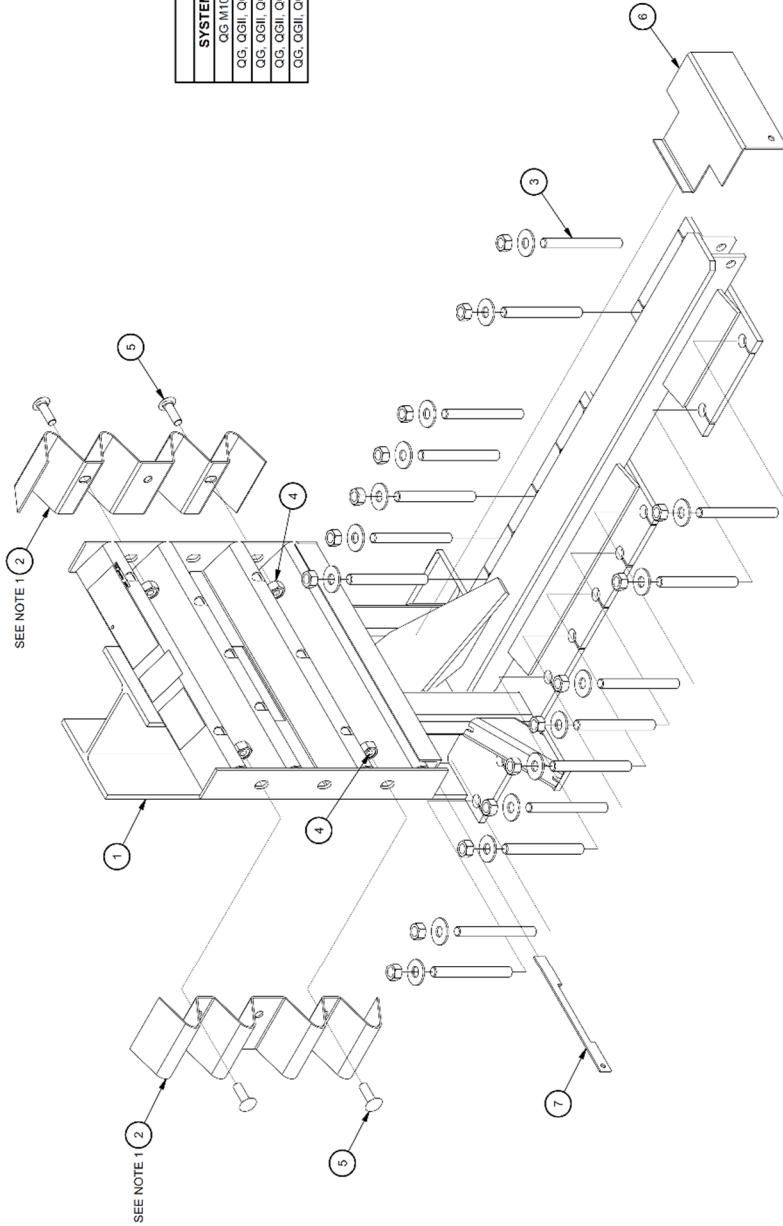
TS Concrete Pad 8" w/Rebar 618686



**TS Concrete Pad 8" wo/Rebar 618686**

PARTS LIST	
ITEM	DESCRIPTION
1	BACKUP, TS, QG W/DECALS
2	PANEL, SIDE, QG
3	ANCHOR KIT, HILT
4	NUT, HX, 5/8", G, RAIL
5	BOLT, RAIL, 5/8"x2", G
6	BRACKET, CARTRIDGE SUPT, TS, BULLOG
7	LOCKING BAR, CARTRIDGE SUPT, QG

TABLE				
SYSTEM	WIDTH	7" ANCHORS	18" ANCHORS	NO ANCHORS
CG, M10	24"	620059	627447	627448
QG, CGII, CG HS	24"	604570	626516	627450
QG, CGII, CG HS	30"	604574	626517	627451
QG, CGII, CG HS	38"	604584	626518	627452
QG, CGII, CG HS	48"	604590	626519	627453



NOTE:  
 1. WHEN TRANSITIONING QUADGUARD SYSTEM TO EXISTING BARRIER,  
 REFER TO THE TRANSITION ASSEMBLY DRAWINGS FOR PROPER USE  
 OF SIDE PANEL, PART NO. 611888 (ITEM 2).

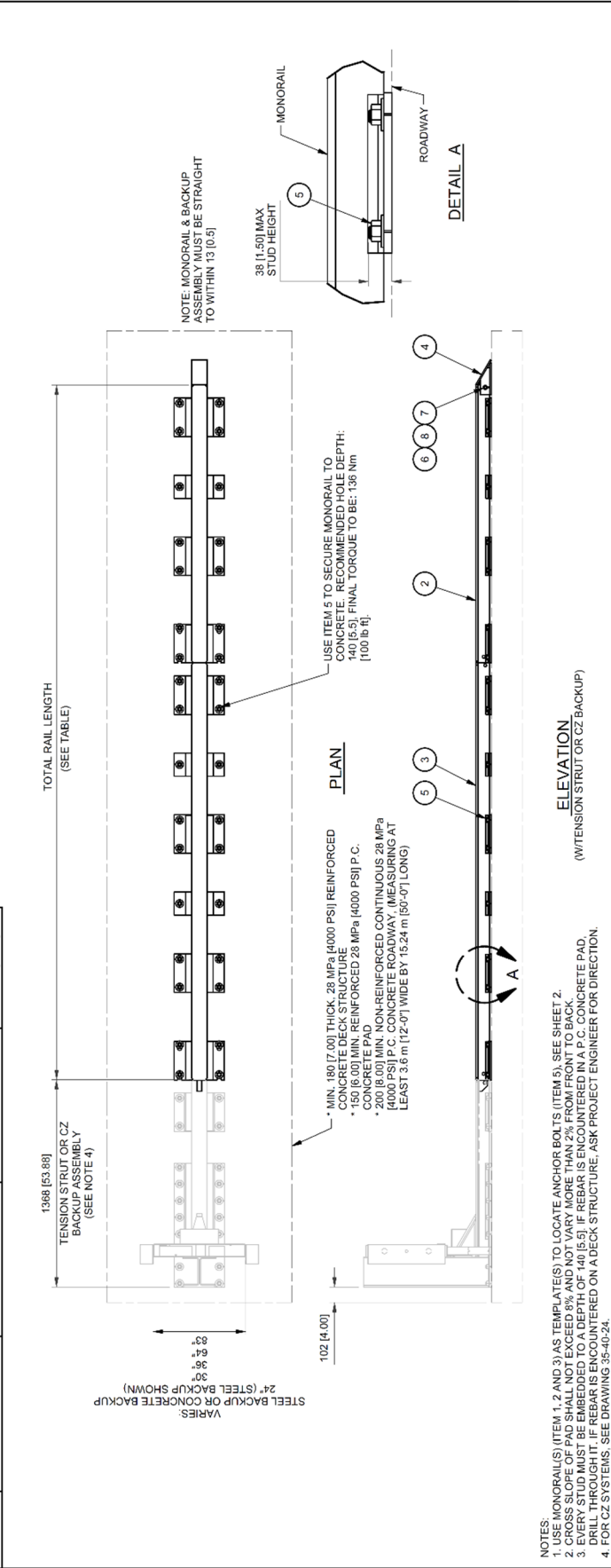
DESIGNED BY <b>R. VENZON</b>	DATE 2/12/2020	REVISION NO. REV	SEE TABLE	QUADGUARD® SYSTEM																								
CHECKED BY <b>B. ECKERT</b>	DATE 2/14/2020	REV	627448.idw	BACKUP ASSY, TS, QG																								
DO NOT SCALE DRAWING																												
<table border="1"> <tr> <td>NO.</td> <td>DESCRIPTION</td> <td>DATE</td> </tr> <tr> <td>1</td> <td>ISSUED FOR CONSTRUCTION</td> <td></td> </tr> <tr> <td>2</td> <td>ISSUED FOR CONSTRUCTION</td> <td></td> </tr> <tr> <td>3</td> <td>ISSUED FOR CONSTRUCTION</td> <td></td> </tr> <tr> <td>4</td> <td>ISSUED FOR CONSTRUCTION</td> <td></td> </tr> <tr> <td>5</td> <td>ISSUED FOR CONSTRUCTION</td> <td></td> </tr> <tr> <td>6</td> <td>ISSUED FOR CONSTRUCTION</td> <td></td> </tr> <tr> <td>7</td> <td>ISSUED FOR CONSTRUCTION</td> <td></td> </tr> </table>					NO.	DESCRIPTION	DATE	1	ISSUED FOR CONSTRUCTION		2	ISSUED FOR CONSTRUCTION		3	ISSUED FOR CONSTRUCTION		4	ISSUED FOR CONSTRUCTION		5	ISSUED FOR CONSTRUCTION		6	ISSUED FOR CONSTRUCTION		7	ISSUED FOR CONSTRUCTION	
NO.	DESCRIPTION	DATE																										
1	ISSUED FOR CONSTRUCTION																											
2	ISSUED FOR CONSTRUCTION																											
3	ISSUED FOR CONSTRUCTION																											
4	ISSUED FOR CONSTRUCTION																											
5	ISSUED FOR CONSTRUCTION																											
6	ISSUED FOR CONSTRUCTION																											
7	ISSUED FOR CONSTRUCTION																											
			627448	REV																								
			1	1 of 1																								

# Tension Strut Backup 627448

TABLE			
NO. OF BAYS	ASSY NO. W/ 7" ANCHORS	ASSY NO. W/ 18" ANCHORS	ASSY NO. W/O ANCHORS
1	611367	611367	611367
2	611332	626525	627543
3	611334	626526	627544
4	611340	626527	627545
5	611343	626528	627546
6	611348	626529	611351
7	611353	627559	627548
8	611354	627560	627475
9	611356	626530	627549
10	611329	627582	627550
11	611330	627583	627551
12	611331	627584	627552

ITEM	DESCRIPTION	TOTAL RAIL LENGTH
1	MONORAIL, 1 BAY, Q.G.	0
2	MONORAIL, 2 BAYS, Q.G.	915 [36.5]
3	MONORAIL, 3 BAYS, Q.G.	1830 [72.0]
4	ENDCAP, MONORAIL, Q.G.	2745 [108.1]
5	ANCHOR KIT, HLT, 1.330mt, 3.4x7, (4)	3660 [144.1]
6	BOLT, HX, 5/8X3 1/2, G5, G	4575 [180.1]
7	WASHER, LOCK, 5/8, G	5490 [216.1]
8	5/8" HX HEX NUT, A563A	6405 [252.1]
9		7320 [288.2]
10		8235 [324.2]
11		9150 [360.2]
12		10065 [396.2]



QUADGUARD® SYSTEM		MONORAIL ASSY, QG	
DESIGNED BY	W. Leedington	DATE	2/13/2020
CHECKED BY	B. Eckert	DATE	2/18/2020
DO NOT SCALE DRAWING			
PROJECT NO.	625637	SCALE	AS SHOWN
REV	A	DATE	1 of 2

Monorail Assembly 625637

PARTS LIST			
ITEM	STOCK NO.	DESCRIPTION	QTY.
1	SEE TABLE	SEE TABLE	1
2	611368	MONORAIL GUIDE.OG.G	2
3	003704	3/4" HX HEX NUT A563 DH	4
4	113655	BOLT.HX 3/4X2.75.G	4
5	118089	WASHER.LOCK.3/4.G	4
6	605446	BRACKET.CARTRIDGE SUPT.DIA.FOLDED.OG.G	2

ASSY. NO.	ITEM 1	DESCRIPTION	WIDTH
625650	625647	DIAPHRAGM.QB.24.OG.G	610 [24.00]
625651	625648	DIAPHRAGM.QB.30.OG.G	760 [30.00]
625652	625649	DIAPHRAGM.QB.36.OG.G	915 [36.00]
606810	607638	DIAPHRAGM.QB.48.OG.G	1219 [48.00]

**NOTE:**  
1. QUADGUARD II REQUIRES THE SHIM KIT. SEE 614050.

<b>DESIGNER:</b> W. Leddington	<b>DATE:</b> 4/13/2016	<b>ISSUED:</b> SEE TABLE	
<b>CHECKER:</b> A. Van Brocklin	<b>DATE:</b> 4/28/2016	<b>FILE:</b> 625650.dwg	
UNLESS OTHERWISE NOTED: ALL DIMENSIONS ARE IN INCHES (R.O.T.) DIMENSIONS IN PARENTHESES ARE IN MILLIMETERS (R.O.T.) UNLESS OTHERWISE SPECIFIED.			
DO NOT SCALE DRAWING			

## Diaphragm Assembly      625650

DIAPHRAGM ASSY, QB, 24"	PART NO.	625650	REV.	B	SHEET	1 of 3
-------------------------	----------	--------	------	---	-------	--------

PARTS LIST	
ITEM	DESCRIPTION
1	SHIM,K

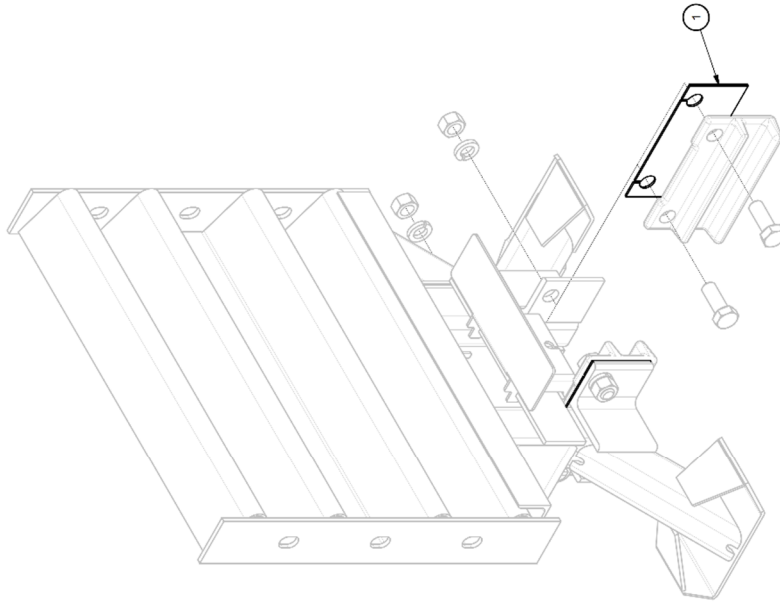


TABLE	
KIT	THICKNESS
614050	12 GA

DRAWN: D. Kohfeld DATE: 2/19/2020 CHECKED: [blank] DATE: [blank] PART: 627518.dwg PROJECT: [blank] SHEET: [blank] TOTAL SHEETS: [blank] TITLE: DO NOT SCALE DRAWING UNIT: [blank] SCALE: [blank]		QUADGUARD® FAMILY SHIM KIT	
627518		1 of 1	

# Shim Kit 627518





PARTS LIST	
ITEM	DESCRIPTION
1	NOSE L,NARROW,OGI,1W,LOGO
2	NOSE R,NARROW,OGI,1W,LOGO
3	BRACKET,CART SUPPORT,NOSE,OG,M
4	BOLT,HX,1/4X3/4,G5,G
5	NUT,HX,1/4,G
6	NUT,HX,5/8,G,RAIL
7	BRACKET,CART HOLD DOWN,OG,M
8	BRACKET,ANGLE,2X1,W,HOLES
9	WASHER,FLAT,3/8X1,G
10	NUT,HX,3/8,G
11	BOLT,HX,3/8X1,G5,G
12	WASHER,FLAT,3/8X2,G
13	BRACKET,PULL-OUT,OG
14	PIPE,3/4 SCH,8X3
15	5/8"X5" GR BOLT,A307
16	WASHER,BAR,10GA,X214,SLOTS

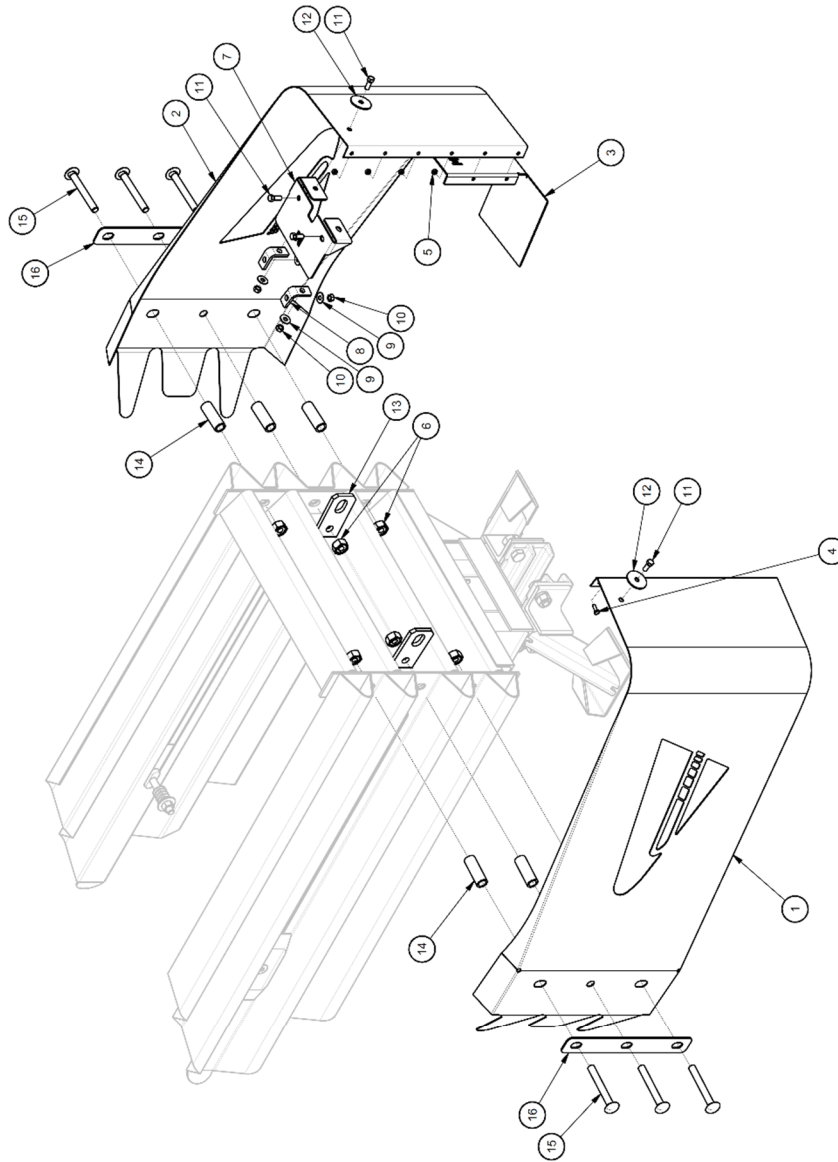
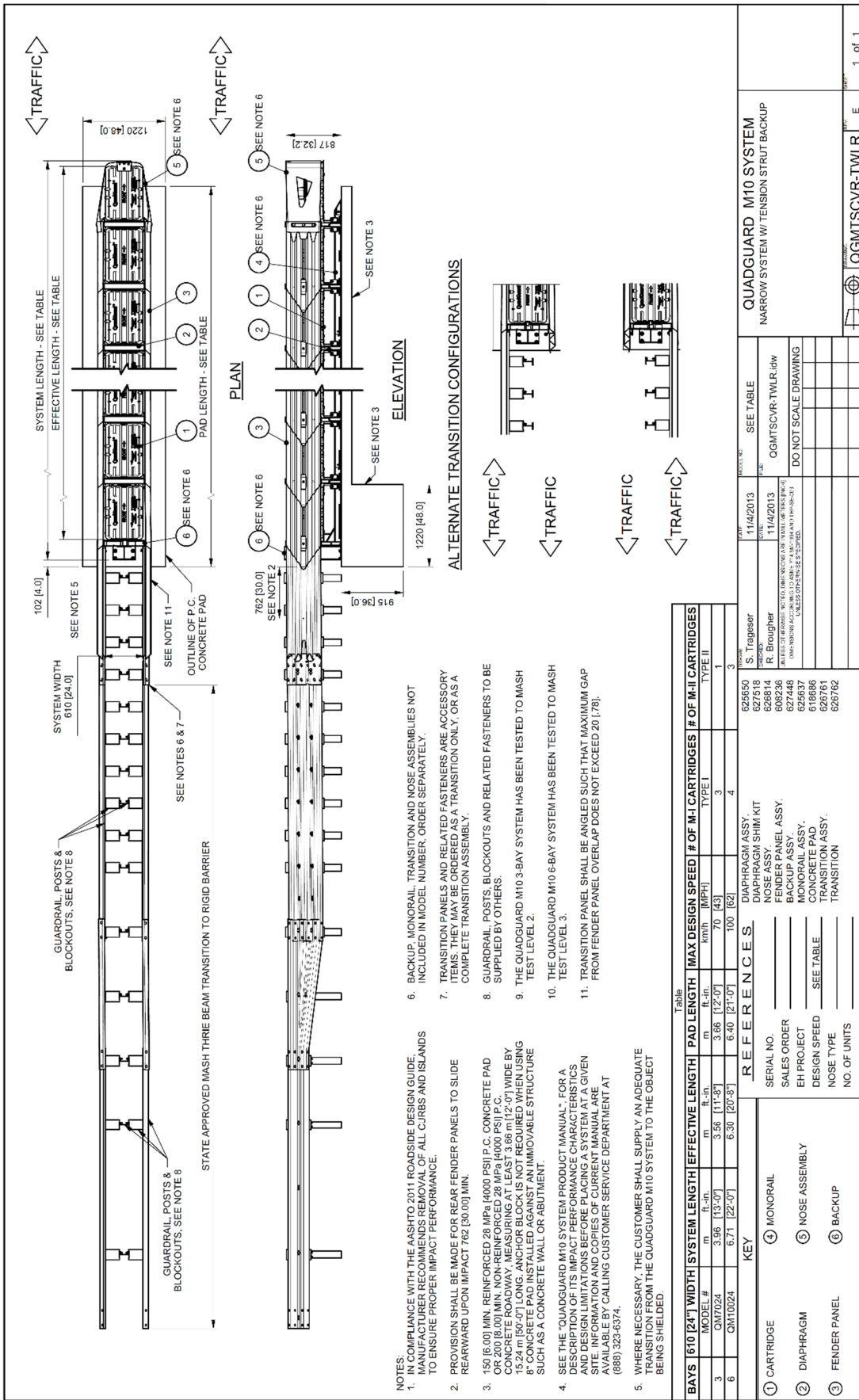


TABLE	
ASSEMBLY	FINISH
617385	GALVANIZED
617424	YELLOW
617425	BLACK

QUADGUARD® M10 SYSTEM NOSE ASSY,NARROW,OGM		REV -		626814		1 of 1	
DESIGNED BY	D. Kohfeld	DATE	11/19/2019	REV			
CHECKED BY	B. Eckert	DATE	1/7/2020	FILE	626814.dwg		
<small>UNLESS OTHERWISE NOTED: A. DIMENSIONS ARE IN INCHES (MM) B. DIMENSIONS ARE IN MILLIMETERS (IN) C. UNLESS OTHERWISE SPECIFIED, ALL DIMENSIONS ARE TO CENTER UNLESS OTHERWISE SPECIFIED.</small>							
DO NOT SCALE DRAWING							

**Nose Assembly      626814**



- NOTES:**
- IN COMPLIANCE WITH THE AASHTO 2011 ROADSIDE DESIGN GUIDE, MANUFACTURER RECOMMENDS REMOVAL OF ALL CURBS AND ISLANDS TO ENSURE PROPER IMPACT PERFORMANCE.
  - PROVISION SHALL BE MADE FOR REAR FENDER PANELS TO SLIDE REARWARD UPON IMPACT 702 [50.00] MIN.
  - 150 [6.00] MIN. REINFORCED 28 MPa [4000 PSI] P.C. CONCRETE PAD OR 200 [8.00] MIN. NON-REINFORCED 28 MPa [4000 PSI] P.C. CONCRETE ROADWAY. MEASURING AT LEAST 3.66 m [12'-0"] WIDE BY 15.24 m [50'-0"] LONG. ANCHOR BLOCK IS NOT REQUIRED WHEN USING 8" CONCRETE PAD INSTALLED AGAINST AN IMMOVABLE STRUCTURE SUCH AS A CONCRETE WALL OR ABUTMENT.
  - SEE THE "QUADGUARD M10 SYSTEM PRODUCT MANUAL", FOR A DESCRIPTION OF ITS IMPACT PERFORMANCE CHARACTERISTICS AND DESIGN LIMITATIONS BEFORE PLACING A SYSTEM AT A GIVEN SITE. INFORMATION AND COPIES OF CURRENT MANUAL ARE AVAILABLE BY CALLING CUSTOMER SERVICE DEPARTMENT AT (888) 325-6374.
  - WHERE NECESSARY, THE CUSTOMER SHALL SUPPLY AN ADEQUATE TRANSITION FROM THE QUADGUARD M10 SYSTEM TO THE OBJECT BEING SHIELDED.
  - BACKUP, MONORAIL, TRANSITION AND NOSE ASSEMBLIES NOT INCLUDED IN MODEL NUMBER, ORDER SEPARATELY.
  - TRANSITION PANELS AND RELATED FASTENERS ARE ACCESSORY ITEMS. THEY MAY BE ORDERED AS A TRANSITION ONLY, OR AS A COMPLETE TRANSITION ASSEMBLY.
  - GUARDRAIL POSTS, BLOCKOUTS AND RELATED FASTENERS TO BE SUPPLIED BY OTHERS.
  - THE QUADGUARD M10 3-BAY SYSTEM HAS BEEN TESTED TO MASH TEST LEVEL 2.
  - THE QUADGUARD M10 6-BAY SYSTEM HAS BEEN TESTED TO MASH TEST LEVEL 3.
  - TRANSITION PANEL SHALL BE ANGLED SUCH THAT MAXIMUM GAP FROM FENDER PANEL OVERLAP DOES NOT EXCEED 20 [1.78].

Table		# OF M1 CARTRIDGES				
BAYS	610' [24.1'] WIDTH SYSTEM LENGTH	EFFECTIVE LENGTH	MAX DESIGN SPEED	# OF M1 CARTRIDGES		
MODEL #	3.96 [13'-0"]	3.66 [12'-0"]	70 [63]	TYPE I	TYPE II	TYPE III
3	3.96 [13'-0"]	3.66 [12'-0"]	70 [63]	3	3	3
6	6.71 [22'-0"]	6.30 [20'-3"]	100 [93]	4	4	4

KEY		REFERENCES	
① CARTRIDGE	④ MONORAIL	SERIAL NO.	DIAPHRAGM ASSY.
② DIAPHRAGM	⑤ NOSE ASSEMBLY	SALES ORDER	NOSE ASSY.
③ FENDER PANEL	⑥ BACKUP	EH PROJECT	FENDER PANEL ASSY.
		DESIGN SPEED	BACKUP PANEL ASSY.
		NOSE TYPE	MONORAIL ASSY.
		NO. OF UNITS	CONCRETE PAD
			TRANSITION
			TRANSITION

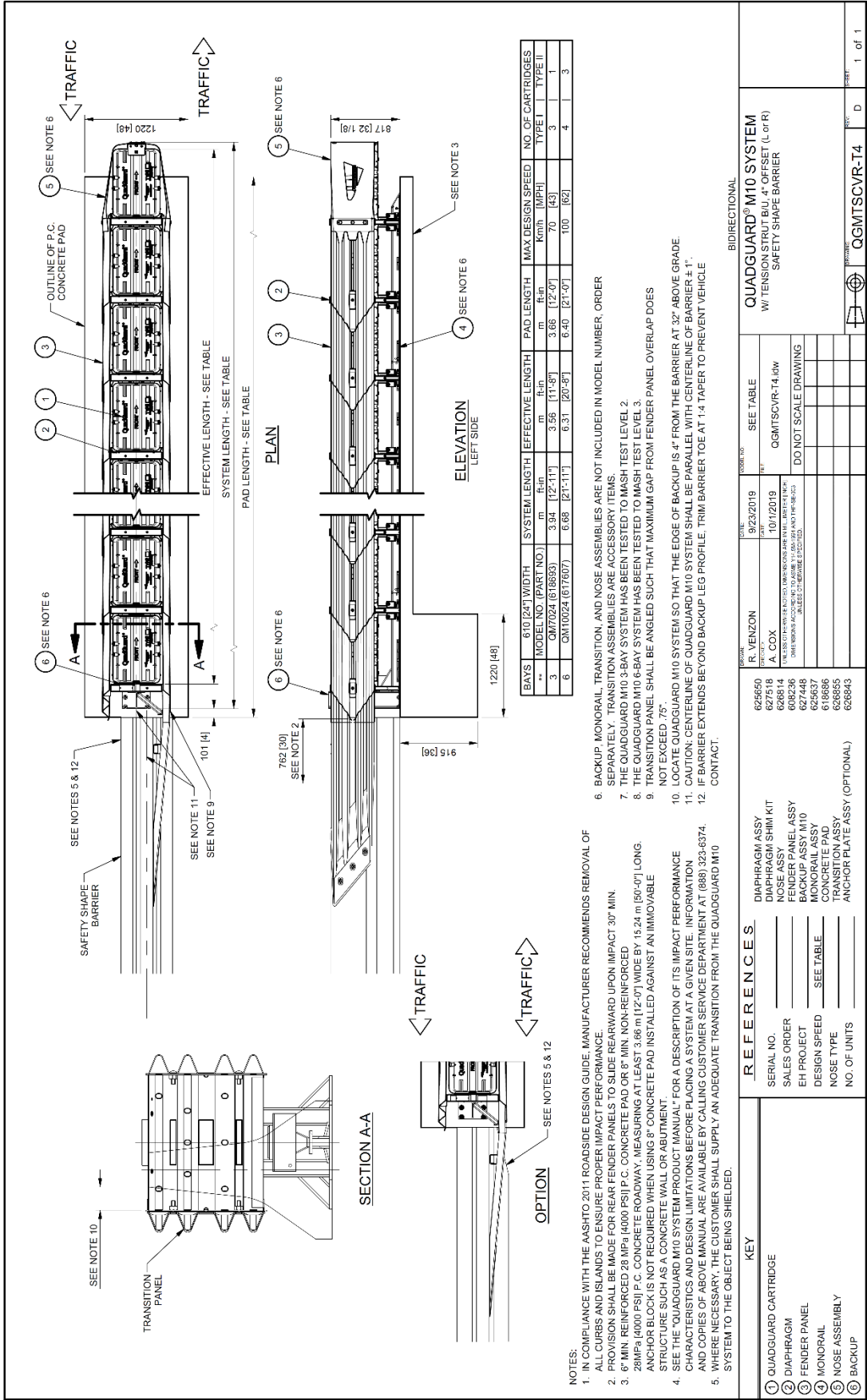
REV	DATE	BY	DESCRIPTION
1	11/4/2013	S. Tregesser	ISSUE
2	11/4/2013	R. Blougher	REVISED

REV	DATE	BY	DESCRIPTION
1	11/4/2013	S. Tregesser	ISSUE
2	11/4/2013	R. Blougher	REVISED

**31" W-Beam Guardrail Transition** **QGM10SCVR-TWLR**





- NOTES:
- IN COMPLIANCE WITH THE AASHTO 2011 ROADSIDE DESIGN GUIDE, MANUFACTURER RECOMMENDS REMOVAL OF ALL CURBS AND ISLANDS TO ENSURE PROPER IMPACT PERFORMANCE.
  - PROVISION SHALL BE MADE FOR REAR FENDER PANELS TO SLIDE REARWARD UPON IMPACT 30" MIN.
  - 6" MIN. REINFORCED 28 MPa (4000 PSI) P.C. CONCRETE PAD OR 8" MIN. NON-REINFORCED 28MPa (4000 PSI) P.C. CONCRETE ROADWAY, MEASURING AT LEAST 3.86 m (12'-0") WIDE BY 15.24 m (50'-0") LONG. ANCHOR BLOCK IS NOT REQUIRED WHEN USING 8" CONCRETE PAD INSTALLED AGAINST AN IMMOVABLE STRUCTURE SUCH AS A CONCRETE WALL OR ABUTMENT.
  - SEE THE "QUADGUARD M10 SYSTEM PRODUCT MANUAL" FOR A DESCRIPTION OF ITS IMPACT PERFORMANCE CHARACTERISTICS AND DESIGN LIMITATIONS BEFORE PLACING A SYSTEM AT A GIVEN SITE. INFORMATION AND COPIES OF ABOVE MANUAL ARE AVAILABLE BY CALLING CUSTOMER SERVICE DEPARTMENT AT (888) 323-6374.
  - WHERE NECESSARY, THE CUSTOMER SHALL SUPPLY AN ADEQUATE TRANSITION FROM THE QUADGUARD M10 SYSTEM TO THE OBJECT BEING SHIELDED.

**REFERENCES**

DIAPHRAGM ASSY	625660
DIAPHRAGM SHIM KIT	627518
NOSE ASSY	626814
FENDER PANEL ASSY	608236
BACKUP ASSY M10	627448
MONORAIL ASSY	625637
CONCRETE PAD	618686
TRANSITION ASSY	626865
ANCHOR PLATE ASSY (OPTIONAL)	626843

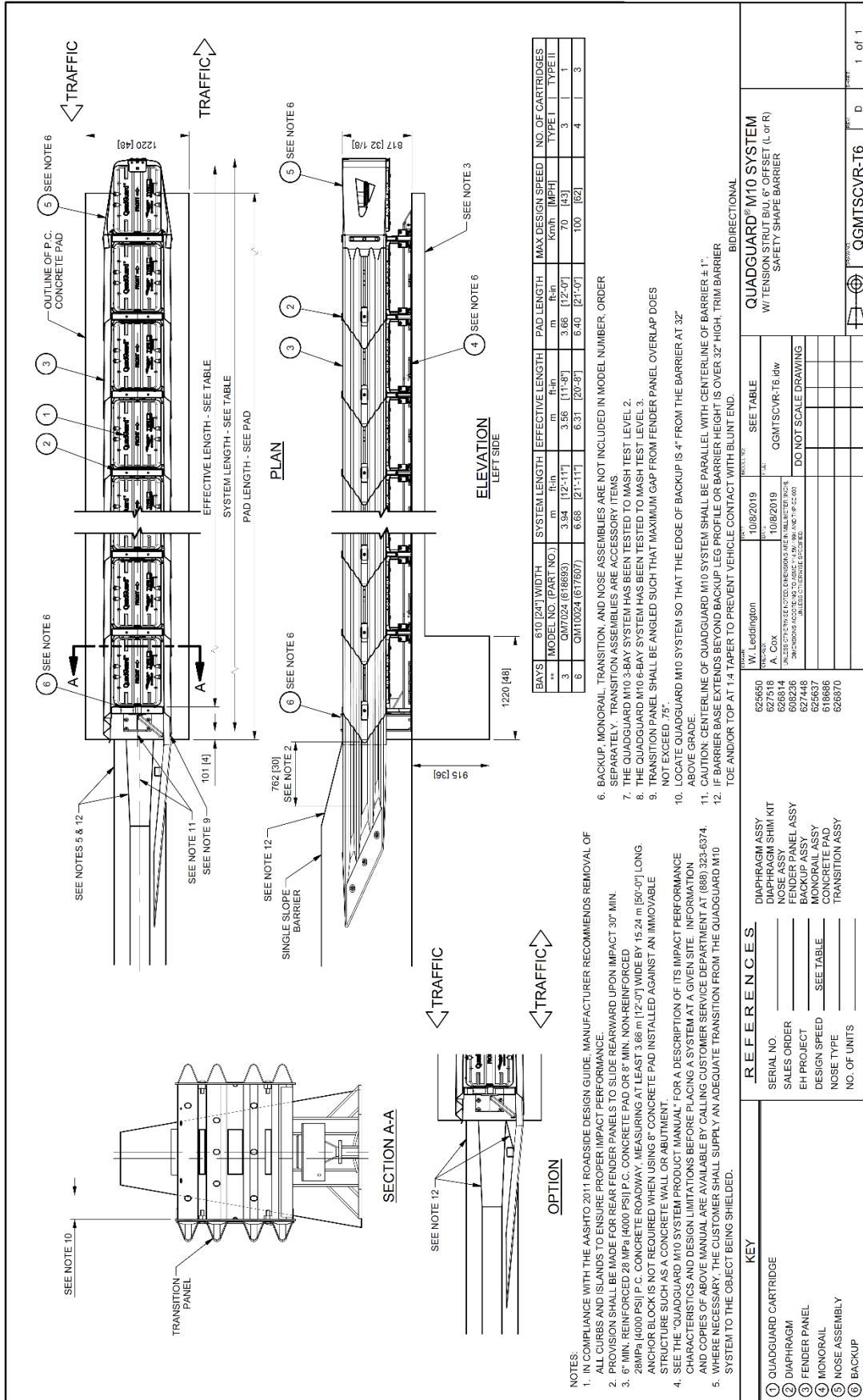
**KEY**

QUADGUARD CARTRIDGE	1
DIAPHRAGM	2
FENDER PANEL	3
MONORAIL	4
NOSE ASSEMBLY	5
BACKUP	6

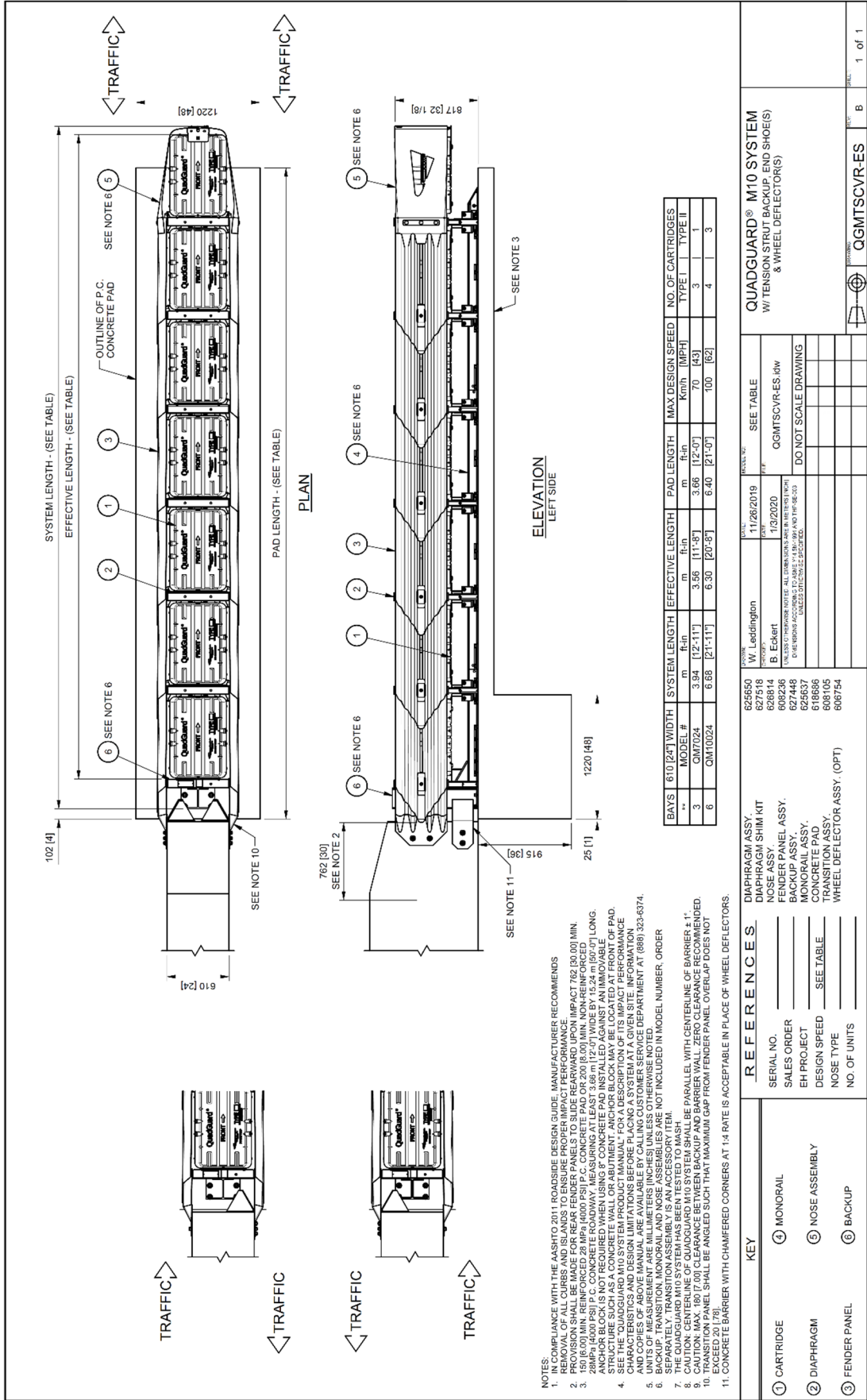
**REFERENCES**

R. VENZON	DATE: 9/23/2019	ISSUE NO.	SEE TABLE
A. COX	DATE: 10/17/2019	ISSUE NO.	QGMTSCVR-T4, REV.
DO NOT SCALE DRAWING			
QUADGUARD M10 SYSTEM			
W/ TENSION STRUT BUI, 4" OFFSET (L or F)			
SAFETY SHAPE BARRIER			
QGMTSCVR-T4			D

# Safety Shape Barrier Transition QGMTSCVR-T4



Single Slope Transition QGMTSCVR-T6



Vertical Barrier Transition QGMTSCVR-ES





**NOTES:**

**NOTES:**

**NOTES:**



For more complete information on Valtir products and services, visit us on the web at [www.valtir.com](http://www.valtir.com). Materials and specifications are subject to change without notice. Please contact Valtir to confirm that you are referring to the most current instructions.

**[WWW.VALTIR.COM](http://WWW.VALTIR.COM)**  
**1.888.323.6374**